

LEB11

LLDC EMPLOYMENT SPACE STUDY



AECOM

WE MADE THAT

LLDC Employment Space Study

Written and produced by:



Rory Brooke
David Wasserberg

XXXXXXXXXXXXXXXXXXXXXXXXXXXX

WE MADE THAT

XXXXXXXXXXXXXXXXXXXXXXXXXXXX

Holly Lewis
Melissa Meyer
Mark Flynn

Commissioned by:
London Legacy Development Corporation

© Copyright November 2015

Contents

Executive Summary	5
<hr/>	
Part 1: Evidence Review	9
1A Review of Employment Space Work	10
1B Policy Review	18
1C SPD Areas	20
<hr/>	
Part 2: Employment Space Typologies	23
2A Workspace Types & Key Characteristics	24
1. Small office type space	26
1.1 Small office space	27
2. Large office type space	32
2.1 Standard large office	33
2.2 Managed workspace	34
2.3 Incubator/accelerator/ co-working space	35
2.4 Bespoke Premises	36
3. Studio type space	48
3.1 Small creative studio	49
3.2 Large creative studio	50
4. Small industrial/warehouse type space	58
4.1 Small industrial space	59
4.2 Maker space	60
5. Large industrial/warehouse type space	68
5.1 Large industrial space	69
5.2 Wholesale / storage space	70
6. Yard space	78
6.1 Business yard	79
<hr/>	
Part 3: Employment & Mix	85
3A Providing Workspace in Mixed Use Developments	86
3B Design Considerations for Workspace & Residential Mix	92
3C Mixed Use Illustrations	106
3D Mixed Use Case Studies	112
<hr/>	
Appendix: Noise mitigation measures	116

Page intentionally blank

Executive Summary

Introduction

The Employment Space Study provides guidance to the London Legacy Development Corporation (LLDC) for the re-provision of B use class employment space within the three geographic areas for which Supplementary Planning Documents are currently being drafted. This guidance refers to six B use class employment space typologies and the key spatial and non-spatial characteristics which should be considered as part of the planning process to ensure successful delivery. Particular attention is paid to the challenge of delivering the six typologies within a mixed use development context that includes both residential and other non-residential uses.

Policy Context

The Legacy Corporation adopted its Local Plan in July 2015 having been found sound during its Examinations which took place during the winter and early spring 2015.

The Local Plan divides up the LLDC area into four sub-areas. It commits the LLDC to preparing three area-based supplementary planning documents (SPD) which are located in sub-areas 1 and 4. Paragraph 14.13 of the Local Plan says the LLDC will provide further guidance to the Local Plan through the following SPDs: Hackney Wick & Fish Island SPD, Pudding Mill SPD, and Bromley-by-Bow SPD.

The Local Plan emphasises the provision or re-provision of new employment space in the LLDC area. In particular, Policy B.1 covers the location and maintenance of employment uses. The Local Plan anticipates that much of the new employment space will be provided within a mixed use format. It also broadly maintains a no net loss approach to employment space. The loss of B2 and B8 floorspace within the LLDC area will only be acceptable in particular circumstances. This means that for development sites with existing B use class provision, existing employment space must be maintained or re-provided. Further discussion of the policy is in Part 1B.

The three SPD areas have distinct identities which means that the guidance in this document will be applied differently in each area. Hackney Wick & Fish Island is Sub Area 1 in the Local Plan. It will deliver approximately 4500 new homes and new neighbourhood centre whilst maintaining the existing level of employment floorspace. The area is large, varied, and historically industrial. While always maintaining a residential sector in its northern part, the traditionally industrial areas have become increasingly mixed use in character. New businesses associated with a range of creative, office and industrial activities have been populating the area in recent years. The Local Plan explicitly seeks to strengthen the foundations of creative and cultural industries in the area to continue to stimulate economic growth. Amongst the three SPD areas, Hackney Wick & Fish Island is furthest evolved towards the LLDC vision.

Bromley-by-Bow and Pudding Mill are located in the Local Plan's sub area 4. New centres are planned for both areas as well as new employment provision. Pudding Mill in particular has been identified as a potential new economic hub for east London and the Local Plan refers to research and development opportunities which could ensure that the area's economic profile is further developed. Since the intensity of development in sub area 4 is less progressed than Hackney Wick & Fish Island, the areas' identity are at an earlier stage in their evolution although there are areas with considerable character. Further detail on the development objective and workspace considerations of all three SPD areas is in Part 1C.

Why is this report necessary?

The LLDC is currently preparing masterplans for the three SPD areas. The masterplans are part of the preparation for the submission of major planning applications. In addition, a considerable number of residential-led, mixed use planning applications have either secured permission or are being progressed through the planning system. A number of pre-application discussions are also underway.

With significant planning activity already underway in the SPD areas it is critical for the LLDC to provide greater detail around its aspirations for the delivery of employment provision.

While the Local Plan articulates the policies for the maintenance and/or re-provision of employment space, this document provides the LLDC with the tools to assist in robustly and effectively engaging with planning applicants to ensure that the employment provision is delivered in a manner which meets the needs of occupants and potential occupants who view the LLDC as a desirable business location.

Without greater detail on the format of which employment provision needs to be delivered, there is the danger that new premises will fail to meet the needs of the market sectors which the LLDC wishes to encourage. In some parts of the LLDC area recently delivered employment space has not been configured in a way which is attractive to the market. As a result, this employment space has not been successfully let.

What makes the delivery of employment space more challenging (but also potentially more viable) in the LLDC context is the need to integrate it within mixed use development. Given the high land prices and need for new homes, much of the development in the LLDC area is residentially-led. It is likely that developers will tend to focus their efforts and expertise on the residential element of development schemes because this will generally generate substantially more value than the employment elements. In some cases the prioritisation of the residential element compromises the employment element such that the space is not found to be attractive to the market. This report seeks to address this challenge by providing a framework and examples of how employment provision can be successfully and effectively integrated into a mixed use development.

The objective and approach

The Legacy Corporation has commissioned this study to inform the guidance that will be contained within area based SPD's; and to provide a framework to aid the preparation and consideration of relevant development proposals, in the light of adopted policies within the Legacy Corporation Local Plan (July 2015). This report has used the following analytic approach:

Review the Employment Space Work

Literature review of the key documents which cover employment space in the LLDC area and central London at large. This included a review of B use class employment typology frameworks developed in other reports by AECOM and We Made That. International publications were also reviewed so as to gain an appreciation of how the delivery of new employment space is approached in other places.

Review of Existing Space and Typologies in LLDC Area

The team surveyed the three SPD areas, took ample pictures, and observed the built environment to develop a greater appreciation of existing employment typologies. While the purpose of this report is primarily to provide guidance for the development of new employment space, a survey of existing space is critical for agreeing the employment typologies for this report.

Develop a Set of Typologies to be considered within a Matrix Framework

Based on the literature review and the survey of the LLDC area the team proposed six employment typologies (and associated sub-categories). The delivery of each of the typologies was considered within different mixed use scale contexts: at the scale of neighbourhood, block and building. The characteristics considered within the matrix are the built form, mixed-use strategy, and design considerations. The matrix format is illustrated overleaf.

A further matrix is created for each typology (and sub category) across the different scales of mixed use development and according to a set of design considerations. The matrix framework on the typology level is included overleaf. In addition to the matrix, mixed use case studies are included to illustrate how employment space has been actually delivered. Key lessons from the case study projects are highlighted.

Research and Draw-up Typology Specifications

The typologies' different spatial success requirements were researched to ensure that physical considerations and requirements are understood and appropriately specified. They were also incorporated into the matrices.

Research and Draw-up Management Arrangements

In addition to the physical requirements of the employment space, the manner in which different employment spaces are managed was incorporated into the matrices.

Diagrammatic Illustrations

Design considerations relating to mixed-use developments are illustrated.

Matrix Format for Overview of Typologies by Mix

Typology	Mix at Neighbourhood Level	Mix at Block Level	Mix at Building Level
Small office	<ul style="list-style-type: none"> — Built form — Mixed-use strategy — Design considerations 		
Large office			
Studio			
Small industrial			
Large industrial			
Yard			

Matrix Format for Individual Typology Design Considerations

Consideration	Mix at Block Level	Mix at Building Level
Access & Servicing		
Environmental Issues		
Exterior & Interior		
Other Design Considerations		

Page intentionally blank

PART 1:
EVIDENCE REVIEW



1A

REVIEW OF EMPLOYMENT SPACE WORK

Literature Review

This section reviews employment typologies that have been defined in various studies. The LLDC Local Economy Study (2014) defined spatial typologies across both office and industrial uses in greatest detail and therefore provides the broadest framework for understanding existing employment space in the LLDC area. Some of the other studies reviewed were more oriented towards the descriptive or focused on only a segment of the overall employment provision market. Other reports focused on the way space is used; the types of firms or activities being accommodated; lease terms/affordability; premises management; and the extent to which different employment uses can co-locate with residential. These features play a critical role in the nature of the provision of employment accommodation and suggest that future provision will have to combine the provision of the appropriate spatial typologies with non-spatial features such as favourable lease terms.

LLDC Local Economy Study (2014)

The spatial characteristics of employment provision in the Local Economy Study provide the basic framework for understanding the current employment base and for informing planning policy. It will help LLDC to effectively engage with developers and provide guidance for the provision of appropriate employment premises. Without it developers might not have sufficient guidance or justification to underpin the delivery of appropriate employment space.

The LLDC Local Economy Study reviewed 653 business units for their spatial characteristics and use class. Based on the survey, seven broad spatial typologies were defined. The report acknowledged that there were instances in which the employment units combined more than one typology such as retail and workshop space. Although not explicit in the report, there are likely to be other instances

Space Typology	Typical Description	Typical Use Classes
Small office-type space	Desk work, any floor, lower ceiling, <500m ² (5,382sq.ft)	B1a/B1b
Large office-type space	Desk work, any floor, lower ceiling, >500m ² (5,382sq.ft)	B1a/B1b
Workshop-type space	Light industrial or artistic studio, any floor, higher ceiling	B1c/B2
Retail-type space	Street frontage, ground level, higher ceiling, <500m ² (5,382sq.ft)	B1a/B1b/B1c
Small industrial/warehouse-type space	Purpose built shed, loading bay, higher ceiling, <500m ² (5,382sq.ft)	B2/B8
Large industrial/warehouse-type space	Purpose built shed, loading bay, double ceiling height, >500m ² (5,382sq.ft)	B2/B8
Yard	Yard with no or only small building	

Source: LLDC Local Economy Study (2014)

in which employment uses are combined with other non-residential uses such as leisure. With the variety of hybrid uses within the LLDC areas, it is likely to be the case that employment space delivered in the future will need to be configured so as to accommodate a variety of different workspace configurations. The table opposite describes the typologies used in the report.

With regard to the reference to ceiling heights in the table opposite, lower ceilings tend to range from between 2.5m to 4.4m. Higher ceilings range from 4.5m up to 8m, with double ceiling heights for large industrial spaces being between 8m up to 12m.

The study found that within each of the typologies there was a variety of business activities including manufacturing, utilities, construction, trade, communications, services, education, culture and the creative. This too reinforces the message that the provision of future space must have the flexibility to accommodate a myriad of uses.

Tech City/City Fringe OAPF Property Market Study (2014)

The Tech City/City Fringe OAPF Property Market Study assessed an area on the periphery of the City that bears similarity to the LLDC area in that it is historically associated with industrial activity but is experiencing considerable change which is causing a reordering of its role in the economy. Like much of the existing employment space in the LLDC area, workspace provision in the City Fringe is to some extent used to service lower-value activities for the benefit of other nearby markets (but have subsequently evolved to establish themselves as important employment drivers in their own right).

The Tech City report identified five typologies which align with the maturity-stage of the companies occupying the space. The evidence showed that the more mature a business is, the larger quantum of space it requires. Given that the City Fringe is currently more oriented towards office-based activity than the LLDC area (which is home to more industrial and creative / design-oriented activities), the space typologies in the Tech City report are not wholly relevant to the LLDC context. Nonetheless it

Space Typology	Size	Relevant information
Artist's studios	<93m ² (1,000sq.ft)	Highly price sensitive occupants
Co-working space	Up to 373m ² (4,000sq.ft)	Space shared by several companies; flexible lease terms
Start-up and other SME space	Up to 373m ² (4,000sq.ft)	Smallest individual units' typically occupied by SME's
Grow on/move on space	Larger than start-up space (>373m ²) but up to 2,787m ² (4,000sq.ft to 30,000sq.ft)	Between SME and corporate occupier
Corporate office space	>2,787m ² (30,000sq.ft)	Established company

Source: Tech City/City Fringe OAPF Property Market Study (2014)

is useful to consider the provision of space which can accommodate companies which reflect a range of maturity-stages.

Accommodating Growth in Town Centres (2014)

This report commissioned by the GLA looked at the ways in which the role of town centres is changing as a result of economic and technological change. The result of these forces on commercial space in town centres has resulted in the need to find new uses for space that is in excess supply vis-à-vis its original purpose. The report suggests that these spaces can be used as Low Threshold Enterprise Space (LTES) that provide workspaces for start-ups and emergent firms. The report provides a set of typologies for the range of spaces that can be found in town centres and the extent to which the spaces could be used as LTES.

The nine typologies in the report are comprehensive and describe the typical occupiers found within them and the associated use classes. The report points to the same rich variety of non-residential spaces that can be found in the LLDC area. However its focus on the locational features of the spaces within a town centre context limits its applicability to the LLDC area.

The table below summarises six of the nine typologies which are most relevant to the SPD areas. The other three typologies (Grade A office space, town centre malls, and out-of-town retail) are found to varying degrees within LLDC but are not particularly useful for the aims of this report.

Premises Type	Spec/Occupiers	Typical Use Classes
Managed office space	Reasonable spec with good quality service provision. Used by SME's and micro businesses	B1 and D1 (non-residential institutions)
Secondary frontage and small units	Basic spec. Independent and local retails, SME's local professional services.	A and D2 (assembly and leisure)
Tertiary high street	Basic to poor spec. Often with large storage areas. Local retailers or services.	A, B1a/c, D2, SG (sui generis)
Market stalls/kiosks	Basic compact trading opportunities for small traders.	A
Back of high street	Basic but providing for a mix of uses with flexibility for changes and upgrades for a variety of SMEs	B1a/b/c, B2, B8, D2, SG
Informal spaces	Very basic, normally with outside storage for small businesses typically in "dirty" trades such as car repair	B1c, B2, B8, SG

Source: Accommodating Growth in Town Centres (2014)

Supporting Places of Work: Incubators, Accelerators and Co-working (IAC) Spaces (2014)

This report looked in finer detail at employment provision that caters to start-ups, micro businesses and SME's. Unlike the Tech City report which was area-specific, office-focused, and provided a comprehensive set of office space typologies, the IAC report focused on models which support emergent office-based enterprises. The report acknowledged that the three employment space categories that the report covered (incubators, accelerators and co-working space) overlapped in terms of the spatial specification. The key differentiator between the categories is the 'type, extent and active involvement of business support' within the facility. While the typologies are relevant to the LLDC context, they are just an element of the full range of relevant workspace typologies.

The table below lists the typologies and their functions:

Typology	Function
Incubator Space	Provides support for businesses in the start-up stage such as training and assistance. Typically provides dedicated space for a firm (instead of co-working space). The number and size of units is variable and flexible.
Accelerator Space	Caters to companies which have the potential to achieve high growth. A high level of support is provided. In London this space is often located within incubator and co-working hubs.
Co-working Space	Provides space where multiple businesses can operate from and combines desk-based work and more physical 'making' activities. The format tends to be open plan where businesses work alongside one another.

Source: Supporting Places of Work: Incubators, Accelerators and Co-working Spaces (2014)

Enterprising Whitechapel – Officer Transformation Manual (2015)

The manual was commissioned by LB Tower Hamlets to develop a better understanding of the economic and business opportunities in the Whitechapel area as a means for informing delivery of facilities / centres to support economic growth through the Whitechapel Vision SPD. Like the IAC report, the manual describes workspaces whose central purpose is to foster the growth of start-ups and SME's. While the Whitechapel SPD boundary is not contiguous with the LLDC area and the two areas have different development aspirations, the document provides relevant guidance for an element of the future LLDC workspace offer.

The manual provides little technical detail about the space that is provided for the facilities. Like the overlap between categories within the IAC study, the manual also illustrates the considerable overlap between its categories. While all the IAC categories are within the Business Incubator typology (in the

table below), they are also likely to be found within Enterprise Centres and Innovation Centres. The focus of the typologies in the manual is on how the space is used and for what purpose. The table below lists the typologies and their function.

Research and viability study of affordable and managed workspaces supporting artistic practices in east London (2014)

This study established six typologies of ‘artistic space’ based on a survey of spaces within the LLDC area. The study defined the spaces according to the functions they perform and how they were used. The study did not provide technical details about size or services. The typologies included studios (including live-work); studios with other provision (such as galleries/production space); music, film and TV productions; performance/events space; gallery; other. The study incorporated the three

relevant SPD areas into its survey and investigated 40 employment premises to derive its typologies.

Artists’ Workspace Study (2014)

Like the preceding LLDC study of affordable and managed workspaces for artistic practices, the Artists’ Workspace Study was narrowly focused on the same sector. The report was commissioned by the GLA and a map on page 19 of the report shows that the artists’ workspaces north of the Thames are concentrated in Hackney and Tower Hamlets. The study contains five categories of workspaces based primarily on the provider of space or the commercial or letting-related arrangements between the provider and artists. The broad categories of analysis of workspaces include provider-specific; tenancy-specific; management-specific; premises-specific; and facilitation-specific.

Centre Typology	Function
Enterprise centres	Focus on business and marketing training but also generally provides subsidised office spaces and services.
Business incubators	Typically specific-sector and provide targeted business support services that cater for that sector. This typology contains the three IAC categories: business incubators, accelerator spaces, and co-working spaces.
Innovation centres	Support high growth businesses in specialised sectors. Offers subsidised office space and services to assist in the start-up phase. Also provision of general business advice. The four sub- categories in this typology include higher education-linked innovation centres; sector-focused innovation centres; general innovation centres; and training provision innovation centres.
Science parks	Campus design with a wide array of facilities. They are based on formal and operational links with universities and research institutions.

Source: Enterprising Whitechapel – Officer Transformation Manual (2015)

LLDC Work-Live Study (2014)

This study focused exclusively on spaces that accommodated both working and living. It reviewed the history of both the formal and informal formats in the LLDC area and further afield. By using the term 'work-live' instead of 'live-work', the emphasis is put on work. This is not by accident as there is a need to ensure that employment uses are prioritised so that they are not lost. The report points to projects which were originally developed as live-work units where the use is now purely residential. Part II of the report provides four models of live-work provision: incubator units, tethered spaces, clustered accommodation and temporary use.

(3,125sq.ft). The report emphasises the importance of providing the market with a range of space options below 465m² (5,000sq.ft).

Industry in the City (2006)

The study addressed the challenge of mixed use development through innovative design solutions. The study used the Lower Lea Valley area as a model to consider the challenge of integrating employment uses with housing. Instead of a set of built typologies the report develops a set of development/design principles, several of which provide useful context for this report. These include flexible building types supported by high floor-to-ceiling heights and flexible internal space/servicing; separate access routes for different uses; control the views of residential units.

Commercial Report: Quantum, Take-up, Values and Trends within LLDC Area (2015)

The 'Commercial Report: Quantum, Take-up, Values and Trends within LLDC Area' reviewed the market for commercial space in the LLDC area. Amongst the data that the report reviewed was that which related to the size of transacted space. The data shows that the majority of office and industrial deals in the area are at or below 465m² (5,000sq.ft). Amongst the 603 transactions the report reviewed, about a third of them were between 93 and 186m² (1,000 and 2,000sq.ft). The average size of these transactions was 130m² (1,400sq.ft). Another 208 deals were between 186 and 465m² (2,000 and 5000sq.ft.) The average size of these transactions was 290m²

International studies

United Kingdom

Releasing the Potential – Approaches for bringing forward employment space (2014)

This report by Nathaniel Lichfield & Partners looked at the challenges to and methods of bringing forward employment space in England. The challenges will be similar to those that the LLDC will face such as landowners having different aspirations; the perception of the risk of developing employment space speculatively; the costs of providing employment space and associated infrastructure; and uncertain viability. The paper looks at the efficacy of a range of different delivery mechanisms and concludes that there is no 'one size fits all' approach to the successful delivery of employment space. Proactive measures by local authorities were seen as highly effective. This includes the production of planning documents and involvement in acquiring and assembling land holdings. Other examples were Salford City Council providing rental guarantees and South Holland District Council securing funding for the development of industrial units.

Barriers to Delivering Mixed Use Development (2009)

This useful and considered report commissioned by the Scottish Government discusses the means to achieving more and better-designed mixed use development. The report recommends that the design process can be used to overcome barriers: establishing a clear shared vision of the mixed use development concept; actively working with partners; having an effective masterplan; and preparing a clear, costed and phased delivery structure and strategy. The report says that the technical challenges of mixed use development can be overcome through technical workshops and cross department teams to resolve problems quickly and develop a shared understanding of complex inter-relationships of different uses.

New Zealand

Mixed Use Town Centres – Good Solution Guide for Mixed Use Development in Town Centres (2005)

This report produced by North Shore City Council in Auckland, New Zealand provides guidance to developers of mixed use development. It explores the nature of mixed use development and then details good practice with regard to a range of design considerations in order to ameliorate conflicts between different uses. It addresses many of the issues which the LLDC is addressing through this report such as access, entrance arrangements, ceiling heights, and servicing. The document includes four case studies. The document draws liberally from the Urban Design Compendium first published in the UK in 2000.

USA

Making Room for Housing and Jobs (2015)

The report addresses the diminished supply of industrial land in New York City. It proposes new approaches to support industrial uses in areas where much of it has been lost to non-industrial uses. Although much of the industrial land that has been lost has been replaced by offices and other commercial uses, the report focuses on the need to prioritise industrial uses over other employment uses within traditionally industrial areas. It is critical of the re-designation of industrial zones into mixed use zones because the policy has resulted in the net loss of industrial space. The loss has come about because there is no explicit requirement to maintain existing industrial uses. It reviews why vertically integrated mixed use buildings are financially challenging and why they have not been built to a significant degree. The paper proposes policy interventions to ensure that new development supports a healthy balance of industrial and non-industrial uses in traditionally industrial areas. The LLDC's policy of prioritising the maintenance of existing B use classes on plots would seem to achieve the same result that the report advocates.

Engines of Opportunity – Reinvigorating New York City’s Manufacturing Zones for the 21st Century (2014)

This paper focuses on how employment space (primarily industrial but also for creative industries and mixed use districts) can be successfully maintained in the face of pressure from other uses. The report points to a number of market influences and planning policies that have caused a diminution of industrial land. The report points to policies in Chicago and Portland which have been successful in maintaining industrial districts. The report recognises the vitality provided by new creative sector businesses and argues for policies that encourage the production of employment space that accommodates those companies while discouraging other commercial uses that have less to do with ‘making’. Finally, the report advocates policies which encourage mixed use development for which an effective policy framework has been lacking.

Quality Growth Toolkit – Mixed-Use Development (2002)

The report provides a high-level framework for delivering mixed use zones in American cities. This is a different approach to that in the UK. Whereas in the US it is more of a carrot approach (supply-side incentives) while in the UK it is the stick (the planning system) which is used to bring forward mixed use. In addition to the development of a policy framework for mixed use, the report advocates incentives and pragmatism. With regard to incentives, the report says the most effective tool is to give density bonuses for mixed use projects so that if certain employment use thresholds are proposed then developers can develop more intensively. With regard to pragmatism, the report advocates that if there is a doubt about the marketability of certain employment uses on certain sites, then leave it out. It cautions against an ideological approach to securing employment space.

POLICY REVIEW

LLDC workspace (re)provision policy

Workspace provision policies detailed in the LLDC Local Plan (2015-2031) seek to maintain the overall levels of employment floorspace through a combination of protection, re-provision, clustering and managed workspace strategies.

The 2014 Employment Land Review of the LLDC area anticipated that jobs in office employment will increase by between 44,700 and 47,400, including jobs associated directly with existing proposals:

- Here East: 7,500, including 5,300 on site
- QEP Legacy Communities Scheme: 4,421
- International Quarter: 26,200
- Strand East (Sugar House Lane): 2,450
- Westfield Stratford City: 10,000
- Chobham Farm: 403

The Local Plan advises on how any new employment floorspace provided should be flexible to accommodate a variety of potential uses and take-up, including variety in access and management. In particular, workspace which can accommodate the types of business currently drawn to the area - primarily creative, cultural and productive industries- is supported, along with workspace that provides for new innovative technology sectors.

A consideration of how workspace (B1 and some B2) can be incorporated into mixed used developments is key, and design precedents for vertical and horizontal integration should be considered. These workspace uses will be protected from future change to residential uses by conditions on a case-by-case basis. Where mixed use development provides workspace suitable for existing local businesses, temporary re-location strategies will be pursued in order to enable these businesses to remain in the LLDC area in the long-term. The Local Plan notes that many of these uses can be accommodated in workshop-type spaces and as such development proposals including this workspace format will be supported.

Policies concerning the protection and development of employment space include:

- Requiring impact assessment for B1a office over 2,500m² (26,910sq.ft) outside of Stratford Metropolitan Centre
- Ensuring new provision is flexible, meeting the needs of a wide variety of end users, contains adequate access and servicing and has no conflict with immediate uses;
- Safeguarding land and buildings within SIL for the balance of B Use Classes in density and floorspace;
- Only allowing proposals providing equivalent use, in density and floorspace, which maintain the existing balance of uses and meeting needs of small- and medium-sized businesses within Locally Significant Industrial Sites (LSIS) and Other Industrial Locations (OILs).

Development proposals on employment land outside of designated workspace clusters or where new uses are proposed within OILs are required to maintain or re-provide equivalent industrial floorspace within B2/B8 use classes or maintain or re-provide equivalent employment floorspace within B1 use classes or significantly increase job densities within B use classes. Proposals within these sites, including conversions, will be considered against:

- proximity of incompatible uses to the existing and proposed use;
- potential reuse of buildings of value for employment;
- re-location strategies showing how existing businesses can be suitably accommodated;
- viability appraisal demonstrating suitability of maintaining or re-providing industrial or employment within the location;
- marketing strategies for two immediately preceding years showing attempts to market the property for employment uses; and
- other overriding factors potentially inhibiting the continuation of employment uses.

Further loss of B2/B8 industrial floorspace within the Legacy Corporation will not be supported except in very particular circumstances where a case is supported by a thorough consideration of the above points. Given the built character of the area it is also

important to note that yardspace is included in the definition of industrial floorspace.

In terms of managed workspace, LLDC policy seeks to retain existing managed and low-cost workspace where viable and where it complements wider plans for the area. New managed workspace and/or low-cost workspace will be acceptable where it:

- Is flexible and able to meet the needs of various end users within B use classes;
- Includes an appropriate management scheme secured through Section 106 Agreements; and
- Does not result in a net loss of employment.

Low cost provision will be supported and secured through Section 106 where:

- Rents are up to 75% of historic market rent for the previous year for the equivalent floorspace in the same area for an equivalent B Class Use;
- It is secured at the current market rate for cultural or creative purposes;
- It is subsidised to reduce the cost to the user for charitable purposes; or
- It establishes robust management links with a registered workspace provider.

The Local Plan advises that provision of managed workspace or low-cost workspace should be clustered to ensure agglomeration benefits and to maximise potential lettings. Links with registered workspace providers will also be supported in the provision of this category of workspace.

1C

SPD AREAS

Bromley-by-Bow

About

- 8ha site, bounded by the Blackwall Tunnel northern approach, River Lea and District Line railway.
- Key adjacent sites: Pudding Mill, Sugar House Lane
- Identified challenges: barriers to connectivity, noise, air quality, compatibility issues, flooding, relationship to adjacent conservation area and river environment.

Development Objectives

Identified in the LLDC Local Development Plan 2015-2031 as “an area of new business and residential communities that find a focus at a new District Centre at Bromley-by-Bow”, the Bromley-by-Bow SPD area is projected to host a mix of new uses. Key to the wider area’s development trajectory is the potential new District Centre designation, coupled with increased residential development which is set to include a significant element of family housing. The Local Plan states that new and re-provided business and retail space should be capable of functioning alongside a mix of uses and provide capacity to support a District Centre. A key consideration will be the integration of the existing or a new Tesco store with other District Centre uses. New business spaces should offer a range of sizes and formats. Other elements of the area’s development include a primary school, playspace, developing the riverside walk, integrating and improving the area’s waterways and through routes and connections. The Local Plan also anticipates a move away from employment to residential uses in the nearby Bromley-by-Bow North scheme.

Workspace considerations

In the provision and re-provision of workspace in the SPD area, the mix of permitted development should:

- Ensure a range in size and formats in retail and other business space;
- Integrate delivery of employment uses with residential and community uses;
- Consider the relationship to retail, office and

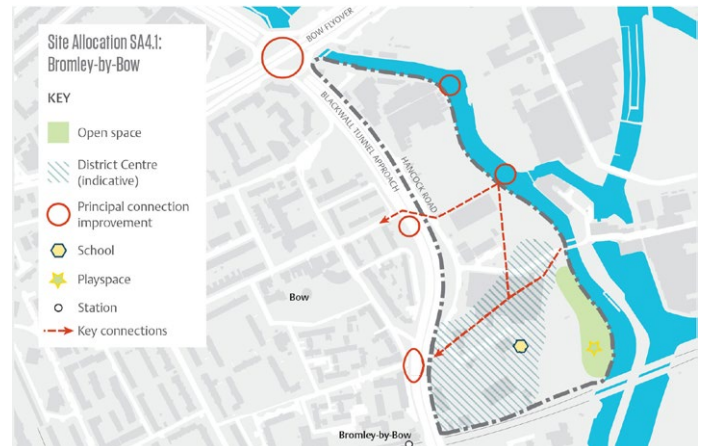

↑ Bromley-By-Bow SPD Area Boundary

employment functions at Sugar House Lane, Three Mills and outside LLDC area west of the A12.

- Employ design considerations suitable to the area in terms of format, flexibility and appearance of employment and retail floorspace;
- Move away from the industrial focus of workspace in the area;
- Proposals for development greater than 18m above ground level will only be acceptable where it meets the tests of Policy BN.10 Tall Buildings.

Hackney Wick & Fish Island

About

- The area has been sub-divided into 9 site area allocations totaling 43.82ha.
- The SPD area has been split in acknowledgment that the area requires a more detailed and locationally tailored policy approach due to its unique character.
- Identified constraints: physical severance, poor internal movement network and legibility, need to improve safety, re-balancing the currently disproportioned mix of uses, access to canal and river frontages, lack of small open spaces and local amenities/services, flood risk.

Development objectives

Development of the Hackney Wick and Fish Island sub-area during the LLDC Local Plan period aims to deliver a “series of mixed and balanced neighbourhoods with places of social, cultural and economic activity” (LLDC, 2015). Approximately 2,000 new homes have planning permission in the area and a further 2,500 could be delivered within the next 15 years. The 4,500 homes anticipated during the Local Plan period include new development planned for East Wick and Sweetwater, sites which include outline planning permission for over 30,000m² (322,917sq.ft) of employment floorspace, leisure, retail and community facilities. In anticipation of this degree of development, the area around Hackney Wick station and the Copper Box Arena has been designated a Neighbourhood Centre in the Local Plan. The sub-area currently contains 40% of the employment land within the LLDC area and 60% of its businesses. Future development should support the strengthening of the creative and cultural industries. Heavier industries and transport uses located towards the south of the sub-area are identified for more established employment requirements.

Workspace considerations

In the provision and re-provision of workspace in the SPD area, the mix of permitted development should:

- Maintain the overall amount of existing employment floorspace, including uses by



↑ Hackney Wick Fish Island SPD Area Boundary

creative and cultural industries and low-cost and managed workspaces;

- Provide a range of employment floorspace including ‘starter’ and move on’ units for small and medium enterprise;
- Provide flexible floorspace for an employment cluster for digital and creative businesses (primarily located at the Here East site);
- Restore and reuse buildings of heritage value for employment uses;
- Conform to the area’s prevailing height of 20m above ground level unless development meets the tests of Policy BN.10 Tall Buildings. Taller buildings may be acceptable within the Neighbourhood Centre where these tests are met.

Pudding Mill

About

- 15.68 ha site, land to the south of QEOP, bounded by the River Lea to the west, City Mill River to the east, Bow Back Creek to the south and the DLR line to the north.
- Identified constraints: connections, contamination, flooding, air quality.

Development Objectives

The Pudding Mill SPD area will provide the framework to deliver a new, medium-density, mixed use neighbourhood. In general heights of up to 21m from the ground floor are considered appropriate for the area. A new Local Centre will be developed adjacent to the Pudding Mill DLR Station, around which taller elements of development should be clustered. Residential development in the area is set to deliver a mix of housing types, with a focus on family housing. The non-residential elements of development in the area will be concentrated along a new east-west street and special-use sites to “allow for incremental growth of employment space with each development parcel” (LLDC Local Plan). The SPD area’s development objectives include a significant element of new and re-provided business floorspace to host a range of employment types. In particular, the LLDC encourages the provision of facilities for higher education, postgraduate study and research, and wider research and development activity. The 2015-2031 Local Plan states that this activity should generally be located within or at the edge of the Metropolitan Centre and Pudding Mill, or at the edge of Sugar House Lane or Here East employment clusters. Particular design considerations identified for Pudding Mill include the area’s waterways, its industrial heritage and flooding considerations.

Workspace considerations

In the provision and re-provision of workspace in the SPD area, the mix of permitted development should:

- Achieve 25% non-residential floorspace cumulatively across the site allocation, with predominantly industrial floorspace use mix in



↑ Pudding Mill SPD Area Boundary

- the area to the west of Cooks Road and around the Crossrail portal;
- Include spaces suitable for small- and medium-sized businesses;
- Maintain the Other Industrial Location (OIL) allocation maintained along the western edge from a buffer to A12;
- Look to opportunities for research and development as identified by the LLDC, in particular around Pudding Mill;
- All buildings proposed above 21m will have to conform to the Local Plan’s Tall Buildings policy.

PART 2:
EMPLOYMENT SPACE
TYPOLOGIES



2A

WORKSPACE TYPES AND KEY CHARACTERISTICS

Using the Part 1 evidence review in combination with on-site observational research, the following set of employment space typologies has been developed. These typologies have been used to structure guidance in relation to the identification and provision of existing and new places of work.

Employment Space Typologies

1. Small office type space
 - 1.1 Small office space
2. Large office type space
 - 2.1 Standard large office
 - 2.2 Managed workspace
 - 2.3 Incubator/accelerator/ co-working space
 - 2.4 Bespoke Premises
3. Studio type space
 - 3.1 Small creative studio
 - 3.2 Large creative studio
4. Small industrial/warehouse type space
 - 4.1 Small industrial space
 - 4.2 Maker space
5. Large industrial/warehouse type space
 - 5.1 Large industrial space
 - 5.2 Wholesale / storage space
6. Yard type space
 - 6.1 Business yard

	Attribute	Specifications Considered
Dimensions	Range of floor area per unit	Average floorspace provision.
	Floor to ceiling heights (internal dimensions)	Average ceiling heights, and particular requirements relating to height.
	Provision possible on which floor	Suitability for typology to be provided at different floor levels (ground, lower, upper).
Access & Servicing	Entrance arrangements	Particular entrance requirements as applicable to staff, servicing, customers.
	Servicing	Regularity of servicing needs, and related spatial needs.
	Vehicle access	Access requirements for different vehicles (staff, customers, deliveries, servicing)
	Waste management	Capacity considerations and access requirements for waste management.
	Transport connections	Particular requirements relating to transport accessibility.
Environmental Considerations	Noise	Associated noise outputs of typical activities in each typology, including consideration of hours of operation.
	Emissions	Associated emissions of typical activities in each typology, including consideration of hours of operation.
Exterior & Interior	Open space/ yard requirements	External/ open space requirements as related to typical activities in each typology.
	Quality of internal environment	Interior / internal specifications and fit out.
	Movement of materials within spaces	Need for materials/equipment to be moved around the workspace unit.
	Interaction with the street	Suitability for interaction with the street, potential for public-facing operations.
Other	Management & tenure	Typical lease arrangements and applicable management structures.
	Typology-specific	Includes: shared facilities/ workspace provider/admin costs

1.0

SMALL OFFICE

TYPE SPACE

Introduction



Introduction

This typology covers conventional office space provision, in particular where it is provided at a small scale - both of individual unit size and quantum of units. Office space at this scale of provision is often found within existing buildings rather than being purpose built (a larger quantum of office floorspace is desirable in new build developments for viability reasons).

Activities are overwhelmingly desk-based. Many features are held in common with Typology 2.0 Large Office Space, as the distinction between the two typologies is primarily one of scale.

Typology Characteristics

- 500m^2 (5,382sq.ft)
- Lower ceiling (2.9 -4.4m)
- Provision on any floor

Target Markets

- Professional and business services
- Creative industries (non vulnerable- i.e. advertising, architecture, computer games, design, designer fashion, film and video)

Typical Use Class

B1

Sub-types

1. Basic office space

1.1 Small office space



Example Scheme: JM Architects Offices, Glasgow

This example shows the refurbishment of an existing high street unit to provide B1 office space with a positive relationship to the adjacent street. Existing architectural features have been left exposed, as have brickwork walls and ventilation servicing. The work area is focused around a large central desk, with a kitchenette, print area and enclosed meeting room at the rear of the unit.

With a floor area of 130m² (1,399sq.ft) in total, this example illustrates efficient use of space by a single tenant occupier.

Image: Dapple Photography

Key Features

- Office unit with small floorspace
- Let as individual unit, typically on conventional office lease arrangement
- No particular external workspace management requirements

Typical Uses

- Professional and business support services
- Other conventional office-based operations

As found in LLDC area

- Typically small number of units, provided on street level or lower-level storeys as part of larger (residential) developments.

SMALL OFFICE TYPE SPACE			
	Attribute	Typology Specification	
		Standard	Ideal
Dimensions	Range of floor area per unit	<ul style="list-style-type: none"> — <500m² (5,382sq.ft) — General rule: less than 10 employees use up to 200m² (2,153sq.ft) 	
	Floor to ceiling heights (internal dimensions)	<ul style="list-style-type: none"> — 2.9 -4.4m ceiling height — For mezzanine floors, assume floor depth of 300 to 500mm (depending on materials) with minimum floor to ceiling requirement of 2.5m. 	<ul style="list-style-type: none"> — Allow raised floor depth of 175mm for flexible servicing. — 2.9m ideal minimum height for mezzanine office space provision.
	Provision possible on which floor	<ul style="list-style-type: none"> — Can be provided at street-level or within building at any floor. — Strength of office identity dependent upon location in building. 	<ul style="list-style-type: none"> — Allowance for street-level business presence desirable, including fascia signage and projecting signs for individual businesses, or directory signage for multiple tenants.
Access & Servicing	Entrance arrangements	<ul style="list-style-type: none"> — Need for staffing / client access only (no large entrance requirements). 	<ul style="list-style-type: none"> — Sufficient space for reception area within unit
	Servicing	<ul style="list-style-type: none"> — Need for good broadband and telephonic infrastructure. — Electrical heating is the most common for simple, dry installation and low capital costs and limited vertical servicing between spaces. — Passive ventilation where possible. 	<ul style="list-style-type: none"> — For a Category A office, a variable refrigerant flow (VRF) system is highly flexible. Condensers to be located outside to the rear of the building.
	Vehicle access	<ul style="list-style-type: none"> — Intermittent servicing with small (transit-sized) vehicles. — Vehicle and cycle parking provided in line with The London Plan. 	<ul style="list-style-type: none"> — Access with 10m flat-bed truck may be required for removals. — Additional cycle parking may be desirable to encourage staff to consider sustainable transport methods.
	Waste management	<ul style="list-style-type: none"> — Need to accommodate / situate appropriate internal /external capacity and accessibility for all waste generated by the full range of potential occupants. 	
	Transport connections	<ul style="list-style-type: none"> — Some need to access to key local transport routes, but not crucial to link to larger regional routes. 	

SMALL OFFICE TYPE SPACE			
	Attribute	Typology Specification	
		Standard	Ideal
Environmental Considerations	Noise	<ul style="list-style-type: none"> Hours of operation within conventional working hours (8am-7pm). Key design features that reduce the type of noise generated in an office environment include glazing, doors, ventilation, building orientation, separating walls, internal walls and floor performance, reverberation controls and room acoustics, external noise acoustics, communal areas. All are mitigated by careful design. 	
	Emissions	<ul style="list-style-type: none"> Generally no disruptive or noxious emissions associated with this typology. 	
Exterior & Interior	Open space/ yard requirements		<ul style="list-style-type: none"> External space not required but can have a benefit in terms of smoking area and lunch spaces. Clear management arrangements required for external space provision.
	Quality of internal environment	<ul style="list-style-type: none"> Developer provision as 'shell and core' fit-out may deter smaller potential occupiers due to capital costs. Daylighting required to work areas although ancillary spaces (kitchens, bathrooms, storage) can be located in deeper plan areas. Quality of separation between offices and other uses in building (if relevant) needed to ensure identity. 	<ul style="list-style-type: none"> 'Category A' fit out is preferred to reduce costs for potential occupiers. Generally including: raised floors, floor coverings, suspended ceilings, extension of the mechanical and electrical services across the rentable space, finishes to the internal face of the external and core walls, window blinds. Refer to British Council for Offices Specification Guide.
	Movement of materials within spaces	<ul style="list-style-type: none"> Minimum requirements to move materials within spaces beyond basic office functions. Goods lift servicing for multi-storey developments (with a minimum loading of 500kg). 	
	Interaction with the street	<ul style="list-style-type: none"> If provided at ground, the need for privacy and security typically prohibits open interaction with the street. For street-facing units, consider fenestration treatments for appropriate balance of privacy/ security and street activation. 	
Other	Management & tenure	<ul style="list-style-type: none"> Let as individual unit, typically on conventional office lease arrangement. No particular workspace management requirements. 	

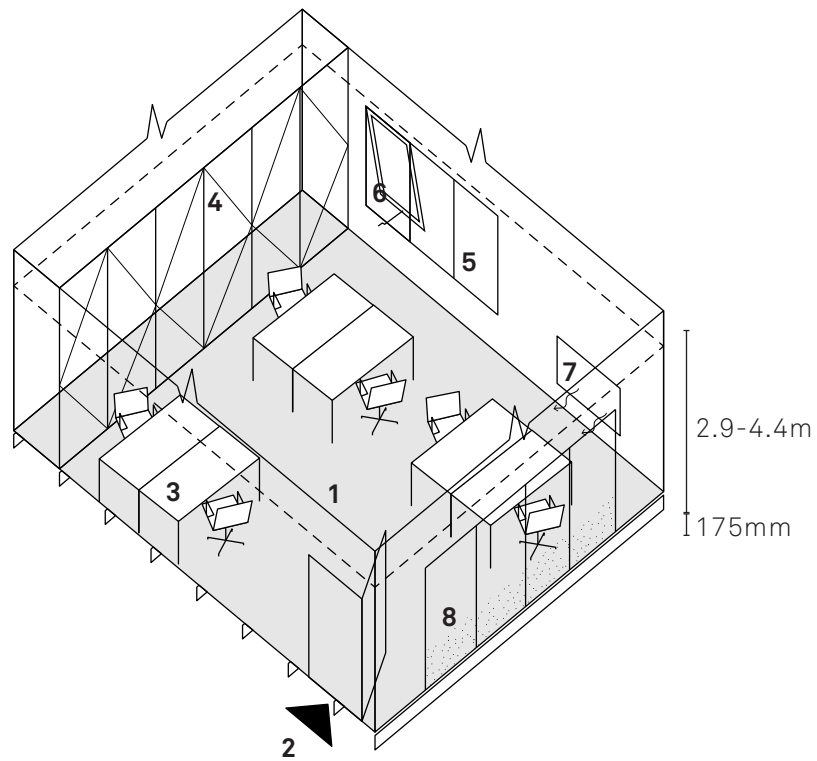

Key:
Standard Small Office Space Provision

1. Less than 500m² floor area
2. Unit-specific entrance
3. Desk-based working
4. Storage
5. Daylighting
6. Passive ventilation where possible
7. Likely electric heating
8. Street facing fenestration and privacy screening

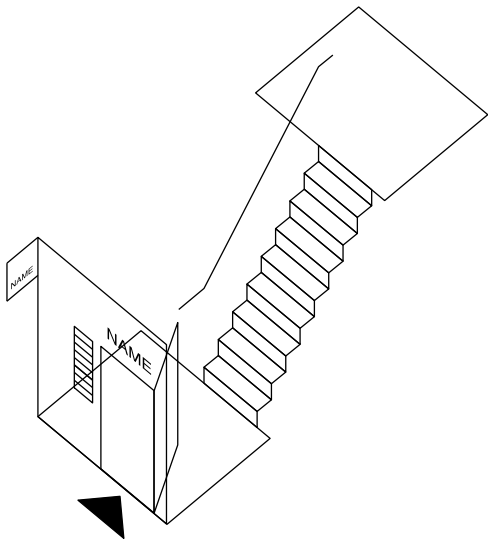

Shared Entrance Area and Directory Signage

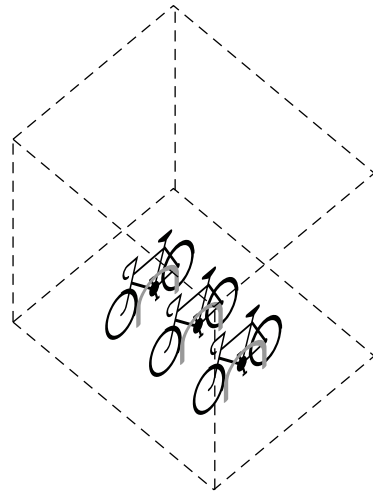

Secure Cycle Storage

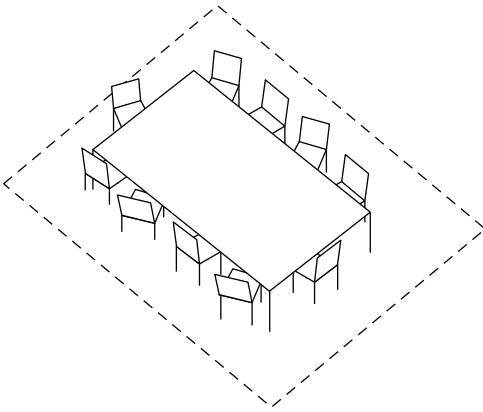

Meeting Space/ Room

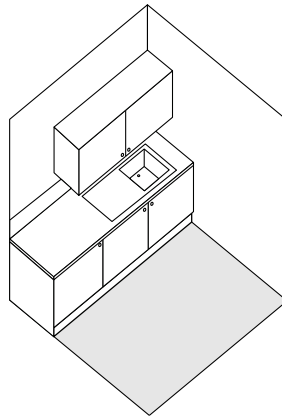

Kitchenette

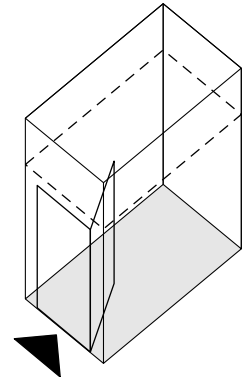

WC

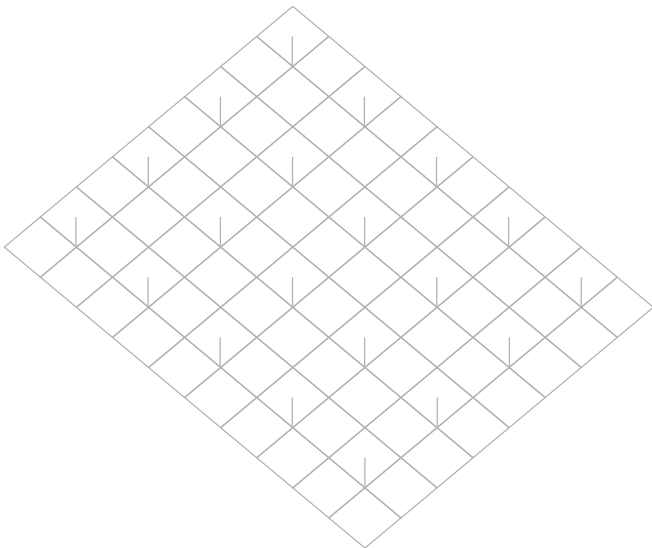

Suspended ceiling

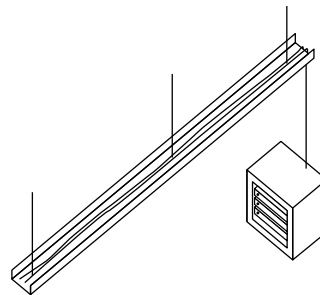

Server/ Data Trays

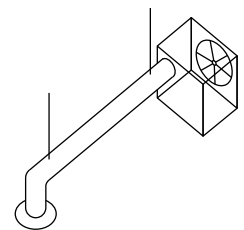

Mechanical ventilation

Small Office Space Typical Components

2.0

LARGE OFFICE TYPE SPACE



Introduction

This typology relates to predominantly desk-based activities, similarly to Typology 1.0. The larger floor areas and quanta in this category are associated with a range of sub-categories that are applicable to a variety of occupiers, ranging from large, corporate organisations using entire buildings or floorplates to sole traders operating in flexible co-working spaces.

Typology Characteristics

- >500m² (5,382sq.ft)
- Lower ceiling (2.9 -4.4m)
- Provision on any floor

Target Markets

- Professional & business services
- Corporate businesses, possibly operating

internationally

- Creative industries (typically commercial uses- i.e. advertising, architecture, computer games, design, designer fashion, film and video)
- Social enterprises
- Start-ups and early-stage enterprises

Typical Use Class

B1

Sub-types

- 2.1 Standard large office
- 2.2 Managed workspace
- 2.3 Incubator/ accelerator / co-working space
- 2.4 Bespoke premises

2.1

Standard large office



Stratford City with tenants occupying entire floorplates.

Example Scheme: 1 Stratford Place

A large quantum of this typology of large office space is consented and/ or constructed around the Stratford City area of the LLDC boundary. 1 Stratford Place is one such example. In total 12,000m² (130,000sq.ft) of 'Grade A' office space is provided, with 1,950m² (21,000sq.ft) floor plates available. Servicing is provided through floor and ceiling voids, and large structural spans allow flexible internal layouts of desk spaces and meeting rooms. The building achieves a BREEAM Excellent rating. A double height monitored reception is provided at ground floor level by the building managers, with further individual receptions on upper floors for each tenant, as applicable.

Key Features

- Office unit with larger floorspace.
- Typically 'Grade A' fit-out, corporate office space.
- Let as individual unit, or multiples thereof, typically on conventional leased arrangement.
- Managed by specialised workspace providers.
- Providers report that typically +2,500m² (26,910sq.ft) floorspace is required for viable operation.

Typical Uses

- Professional and business support services
- Other conventional office-based operations

As found in LLDC area

- Typically provided in dedicated large-scale office buildings e.g. The International Quarter,

2.2 Managed workspace



As found in LLDC area

- May be purpose built, or within existing buildings, as at Stratford Workshops.

Example Scheme: Pillbox, Bethnal Green

The Pillbox is a recently completed development by Workspace Group. It offers a range of office sizes from 10-70m² (104-749sq.ft), as well as a co-working space and communal facilities such as: a cafe, secure cycle racks, gym, meeting rooms and showers. Space is available between £70-90/sq.ft per annum.

Situated within a refurbished former pharmaceutical manufacturing building, the 'retained industrial features' are a marketed feature of the building. Key target markets are creative, tech and publishing businesses. In addition to space provision, the following services are also available to tenants: 24 hour access, bureau facilities, CCTV and a centre manager.

Key Features

- Office units ranging from small cellular spaces (10m², 105sq.ft) to medium sized spaces (140m², 1,500sq.ft).
- Let as individual unit or workspace within a unit from a workspace provider managing a number of units, common areas and shared facilities e.g. meeting rooms, cafes.
- Workspace providers generally require a critical mass of units/workspace to make management model viable.

Typical Uses

- Professional and business support services
- Other conventional office-based operations

2.3 Incubator/ accelerator/ co-working space (IAC)



As found in LLDC area

- Typically large floorspace in previously industrial or warehouse use building, provided above street-level, for example 90 Main Yard.

Example Scheme: Central Working, Whitechapel

Dept W, a multi-purpose workspace hub located on Mile End Road, has been set up specifically with tech uses in mind. Central Working, an award winning start-up office venue operator, are the first tenants to be operating in the building. In total, 2,050m² (22,000sq.ft) of space has been refurbished to provide workspace, a shared reception, flexible meeting rooms, breakout areas, a cafe and an events space for up to 140 people. Aesthetically, Dept W is defined by a 'raw industrial' approach to interior fit-out, with exposed servicing and architectural features.

Central Working are currently running two different incubator/accelerator programmes in collaboration with Barclays and Techstars (Microsoft).

Key Features

- Let as individual desk space or workspace within a unit from an IAC provider.
- Leasing agreement generally more flexible or short-term than conventional office space or managed workspace.
- Providers require adequate floorspace to sub-divide into appropriate workspace units (typically 5-50 desks).

Typical Uses

- Start-ups, early-stage businesses
- SMEs and micro businesses more reliant on non-local trade
- Social enterprise hubs
- Freelance/ part-time workers (often in creative sector services)

2.4 Bespoke premises



Key Features

- Large-scale premises with bespoke spatial requirements, not suitable for provision through generalised typology.
- Premises often related to research and development operations, either affiliated to particular company or to a larger research institute.
- Premises are designed and constructed to specific standards according to needs of the client.

Typical Uses

- Research & development operations
- Product design and development
- Bespoke manufacturing & production
- Professional and business support services

The case study design considerations detailed below take a bioscience research facility as a key example of the type of bespoke premises which might be provided in the LLDC area, although these should not be taken as detail appropriate to other bespoke premises. Design considerations and attributes will vary across different premises types.

Bioinnovation centre/ Bioincubator¹:

- Multi-occupied facilities providing laboratory space to SMEs and high-growth start-ups requiring specialist ‘plug and play’ laboratories and services.
- Flexible bioinnovation centre building types are commonly designed with commercial, laboratory and office space closely oriented.
- This orientation maximises productivity and convenience for researchers as office space, write-up space, laboratory and support spaces are all within close reach.
- Existing assessments of the LLDC area’s capacity to host a bioinnovation centre note that a 9,290m² (100,000sq.ft) site could deliver 7,432m² (80,000sq.ft) of lettable space, potentially doubling London’s current bioincubator capacity.

Design specifications:

- Rented laboratory spaces typically range in size from 50m² (570sq.ft) to 200m² (2,200 sq.ft), arranged in a rational, compartmentalized plan.
- Security and the protection of intellectual property are paramount, and this should be reflected in the building’s design and layout.
- Deep suspended ceilings contain fume-hood extraction and vents, and are serviced by a large plant area on the roof.
- Reinforced floor plates are needed to support the weight of specialist fume extraction equipment. This makes it difficult to adapt

1 ‘Pudding Mill Urban Biopark Development Report’, Rick Mather Architects, and ‘Pudding Mill Urban Biomedical Park: Developing the concept (Draft), CAM-SCI, and ‘Supporting Places of Work: IAC Spaces Report’, URS

existing buildings.

- Building should be designed and managed to be operational 24/7. Most importantly this requires a permanent security presence, as well as the capability to “lockdown” the building at a moments notice.
- This is in order to both protect the IP of tenants, as well as to accommodate on-site clinical trials, which require stringent security measures comparable to those found in major hospitals.
- Specialist wet lab rooms and workspace, reconfigurable to tenants requirements
- Individual labs should be split between a wet lab, fitted out with work benches and extractor facilities, and an office space, complete with kitchen and clean write up areas
- No visibility between lab units and limited interaction between business due to sensitive nature of work and high privacy requirements
- Some shared facilities, including access to highly specialised lab equipment and a waste disposal room may be desirable.
- To minimise visual impact and perceived building height, setbacks and sloping roofs can be utilised.
- To avoid basement construction costs, plant space can be positioned above ground as podium.
- In this typology, where a multitude of research opportunities exist and future flexibility is essential, a large portion of the building area is taken up by plant for ventilation, extract and servicing.
- Typically these servicing areas are located in the basement, between floors in interstitial service voids and at roof level.

Example Scheme: MRC Laboratory of Molecular Biology

The Laboratory of Molecular Biology (pictured, above left) is a purpose-built building providing around 27,000m² (290,000sq.ft) of scientific workspace, accommodated over three floors. Facilities include: a containment suite, computing, media preparation, chemistry labs, X-ray facilities, electron and optical microscopy, mass spectrometry, fermentation, stores, mechanical, electrical and computing workshops, maintenance and lab management.

Servicing needs in such a building are highly specialised. In this case, heavy plant is housed in a separate energy centre and in four stainless steel-clad towers linked to the building. This removes weight and sources of vibration from the laboratory, allowing a more lightweight construction. Full height interstitial service voids house all ductwork, pipes and services between each floor of workspace, effectively creating a 6-storey building with three floors of workspace. These interstitial voids enable services to be located laterally between floors, and can be maintained without disruption to laboratories and workspaces below.

The main laboratories are in 1000m² (10,764sq.ft) modules, each housing 40 benchworkers together with write-up spaces, group leader offices and local equipment rooms. Benches are double length (4m for two people), in 3.3m wide bays. The plan is semi-open, with walls separating pairs of bays from adjacent single-bay equipment areas. The building cost £212 million to deliver and is a key component in the development of the Cambridge Biomedical Campus; one of the largest and most internationally competitive concentrations of healthcare-related enterprise in Europe.



Example Scheme: Queen Mary Bioscience Innovation Centre²

Completed in 2012, the Queen Mary Bioscience Innovation Centre (QMB) in Whitechapel, East London is the largest purpose-built commercial laboratory space incubator in the city. The centre provides commercial lab grow-on space- the only facility in London to do so- designed to accommodate those start-ups which have expanded beyond university laboratory or standard business incubator spaces.

The centre totals 4,530m² (48,780 sq.ft) internal floorspace, including 3,530m² (38,000 sq.ft) of incubator space and 1,000m² (10,780 sq.ft) of university and medical school space. The

2 'Supporting Places of Work: IAC Spaces Report', URS

centre operates 24-hours/day and is managed by a dedicated workspace operator (Queen Mary BioEnterprise Ltd). Rents range from £55-£65/sq.ft per annum (not including business rates).

Lab spaces available to rent range from 50m² (570sq.ft) to 200m² (2,200 sq.ft). Security and the protection of intellectual property are key concerns for tenants and as such there is no visibility between labs. Workspaces include special wet lab rooms and workspace which tenants can reconfigure to suit their needs. Wet labs include workbenches and extractor facilities, while workspaces include office space, clean write up areas and kitchens. The high level of services required for the laboratories are directed through one, very large duct, four meters by six meters, which feeds the whole building.

Deep suspended ceilings contain fume-hood extraction and vents, and are serviced by a large plant area on the roof. Reinforced floor plates are needed to support the weight of specialist fume extraction equipment. This makes it difficult to adapt existing buildings, and was a key factor in the decision to design a purpose built facility for QMB.

The total construction and fit-out costs totalled £30m, with £7m granted from LDA and £6m covered by QMU.

Page intentionally blank

LARGE OFFICE TYPE SPACE			
	Attribute	Typology Specification	
		Standard	Ideal
Dimensions	Range of floor area per unit	<ul style="list-style-type: none"> — >500m² (5,382sq.ft) — General rule: 50 employees = up to 1000m² (10,764sq.ft), 50-250 employees = 5,000m² (53,820sq.ft) For managed workspaces: <ul style="list-style-type: none"> — Individual units generally range from 15-200m² (162-2,153sq.ft) but some larger units can be up to 2,000m² (21,528sq.ft) For IACs: <ul style="list-style-type: none"> — Spaces range from 30-150m² (323-1,615sq.ft), clustered in a group of minimum 5 units. 	<ul style="list-style-type: none"> — Contiguous floor sizes of 500m²-2500m² (5,382-26,910sq.ft) provide the most usable spaces. Landlord efficiency, expressed by the ratio of Net Internal Area to Gross Internal Area should be 84-87% if the building is mid- to high-rise or 90% + if low-rise. Tenant efficiency, expressed by the ratio of usable area to Net Internal Area, should be 85%. For managed workspace: <ul style="list-style-type: none"> — Providers find mid-range sizes units (47-93m² /500-1,000sq.ft) most difficult to let
	Floor to ceiling heights (internal dimensions)	<ul style="list-style-type: none"> — 2.9 -4.4m ceiling height — For mezzanine floors, assume floor depth of 300 to 500mm (depending on materials) with minimum floor to ceiling requirement of 2.5m. 	<ul style="list-style-type: none"> — Allow raised floor depth of 175mm for flexible servicing. — 2.9m ideal minimum height for mezzanine office space provision.
	Provision possible on which floor	<ul style="list-style-type: none"> — Can be provided at street-level or within building at any floor. — Strength of office identity dependent upon location in building. 	<ul style="list-style-type: none"> — Allowance for street-level business presence desirable, including fascia signage and projecting signs for individual businesses, or directory signage for multiple tenants.
	Entrance arrangements	<ul style="list-style-type: none"> — Need for staffing / client access only (no large entrance requirements). 	<ul style="list-style-type: none"> — Shared reception is desirable for multi-tenanted buildings. — Individual tenants may also require dedicated reception areas within their demise For IACs: <ul style="list-style-type: none"> — Sufficient space for reception area within unit
Access & Servicing	Servicing	<ul style="list-style-type: none"> — A variable refrigerant flow (VRF) system is highly flexible. Condensers to be located outside to the rear of the building. — Risers for voice, data and other services, should be no less than 2% of gross floor area, with capacity to knock through another 2% easily if the need arises. Areas containing the risers should be widely distributed to avoid cable bottlenecks. — A communications room measuring 2.0 x 2.0m should serve each 500m² (5,382sq.ft) of GFA. 	<ul style="list-style-type: none"> — Natural ventilation is more psychologically acceptable than any mechanical forced system. However, most large office situations adopt ducted vent system. However, this increases installation, running and maintenance costs.

LARGE OFFICE TYPE SPACE			
	Attribute	Typology Specification	
		Standard	Ideal
Access & Servicing	Servicing	For IACs: <ul style="list-style-type: none"> — Need for good broadband and telephonic infrastructure — Electrical heating is the most common for simple, dry installation and low capital costs and limited vertical servicing between spaces. 	For IACS: <ul style="list-style-type: none"> — For a Category A office, a variable refrigerant flow (VRF) system is highly flexible. Condensers to be located outside to the rear of the building.
	Vehicle access	<ul style="list-style-type: none"> — Intermittent servicing with small (transit-sized) vehicles. — Vehicle and cycle parking provided in line with The London Plan. 	<ul style="list-style-type: none"> — Additional cycle parking may be desirable to encourage staff to consider sustainable transport methods. Showers and changing areas should also be provided. For IACs: <ul style="list-style-type: none"> — Access with 10m flat-bed truck may be required for removals.
	Waste management	<ul style="list-style-type: none"> — Need to accommodate and situate appropriate internal / external capacity and accessibility for all waste generated by the full range of potential occupants. 	
	Transport connections	<ul style="list-style-type: none"> — Would benefit from access to key local and regional transport routes to facilitate regional customer access. For IACs: <ul style="list-style-type: none"> — Some need to access key local transport routes, but not crucial to link to larger regional routes. 	
Environmental Considerations	Noise	<ul style="list-style-type: none"> — Hours of operation within conventional working hours (8am-7pm). — Key design features that reduce the type of noise generated in an office environment include glazing, doors, ventilation, building orientation, separating walls, internal walls and floor performance, reverberation controls and room acoustics, external noise acoustics, communal areas. Refer to the Appendix for detailed noise mitigation measures. 	
	Emissions	<ul style="list-style-type: none"> — Generally no disruptive or noxious emissions associated with this typology. 	

LARGE OFFICE TYPE SPACE			
	Attribute	Typology Specification	
		Standard	Ideal
Exterior & Interior	Open space / yard requirements		<ul style="list-style-type: none"> — External space not required but can have a benefit in terms of smoking area and lunch spaces. Clear management arrangements required for external space provision. — Larger workspace providers see outdoor spaces as preferable for supporting social work environment and catering for events.
	Quality of internal environment	<p>For large office & managed workspace:</p> <ul style="list-style-type: none"> — Generally higher spec, institutional and high quality, growing influence of BREEAM ratings. — Flexible open plan space. — Glass-to-core depths of 9-12m allow room for cellular office space or open plan plus storage space. — Glass-to-glass depths of 13.5-18m, allow two or three zones of space or open plan plus storage, office and support space. <p>For IACs:</p> <ul style="list-style-type: none"> — 'Ready to occupy' spaces provided through sub-division of open plan space, with enough built-in capacity to allow companies to take up less/more space as their enterprise develops (need daily flexibility). — Little evidence that success of co-working is dependent on providing high quality work environments - many have basic provisions with low cost fit out. — Need for some enclosed meeting/projects areas for private meetings and potentially disruptive activities like tele-conferencing. 	<p>For large office & managed workspace:</p> <ul style="list-style-type: none"> — 'Category B' fit out can offer a higher level of specificity to tenants and may include: installation of cellular offices, enhanced finishes, conference/meeting room facilities, reception area, IT and AV installations, tea point/kitchen and furniture. — Flexibility of position of internal walls improves adaptability for future occupants. <p>For IACs:</p> <ul style="list-style-type: none"> — Provision will depend on target market — Co-working has an emphasis on informality & laptop working, while incubator & accelerators can require more sub-division into discrete units (like managed workspace), while an R&D incubator might need to provide specialist utilities, floor tolerances and isolation units etc.
	Movement of materials within spaces	<ul style="list-style-type: none"> — Review vertical and horizontal access transfer of materials (furniture, stationery / office supplies, office equipment – copiers, etc., post, couriers, food deliveries maintenance access, maintenance access to outdoor space, etc.) — Reduce potential bottlenecks and conflicts and noise between occupants. 	<ul style="list-style-type: none"> — Goods lift servicing for multi-storey developments (with a minimum loading of 500kg). — Dedicated service entrance.

LARGE OFFICE TYPE SPACE			
	Attribute	Typology Specification	
		Standard	Ideal
Exterior & Interior	Interaction with the street	<ul style="list-style-type: none"> — If provided at ground, the need for privacy and confidentiality typically prohibits open interaction with the street. — For street-facing units, consider fenestration treatments for appropriate balance of privacy/ security and street activation. <p>For IACs:</p> <ul style="list-style-type: none"> — Open-access facilities and workshops benefit from ground floor location where they are visible and benefit from good access and servicing. 	<ul style="list-style-type: none"> — Reception areas can provide opportunities for secure and active street-level uses. <p>For IACs:</p> <ul style="list-style-type: none"> — Potential for co-working and ground floor café spaces to be combined.
Other	Management & tenure	<ul style="list-style-type: none"> — Let as individual unit, typically on conventional office lease arrangement. <p>For managed workspaces:</p> <ul style="list-style-type: none"> — Generally leased or licensed by the owner or landlord on a short term basis (e.g., 1 month to 3 years) although in some instances it requires up to 5 years (with break clause for three years). — The landlord or owner maintains an active presence on site. Discrete units are let as well as hot desk/ managed workspace. There is often communal space and a café. — Rental levels are flexible depending on occupant, space, and lease terms. <p>For IACs:</p> <p>i. Incubator space:</p> <ul style="list-style-type: none"> — Incubator providers (or their underwriters) may seek a share in the future profits or a minority stake in their occupants' business as a pre-requisite to taking space and providing support services. New users are typically start-ups without significant revenues. They are selected by the provider through a competitive process. — Incubators typically provide support / advice for start-up businesses for a period of one to two years during the early stage of development. Businesses generally stay within incubator environments for 18 months to five years. 	<ul style="list-style-type: none"> — Many providers seek to retain tenants over the long-term, and as such buildings with a range of workspace sizes are desirable as they allow for the workspace to accommodate businesses through different growth phases. — A range of spaces also allows providers to subsidise different workspace provisions across one site. <p>For managed workspace:</p> <ul style="list-style-type: none"> — Management by a specialist commercial provider is more likely to create successful workspaces. — Larger providers report a desirable minimum of around 2,788m² (30,000sq.ft) to deliver viable managed office space. — Larger providers prefer freehold arrangements and pre-existing subdivided buildings are desirable.

LARGE OFFICE TYPE SPACE			
	Attribute	Typology Specification	
		Standard	Ideal
Other	Management & tenure	<ul style="list-style-type: none"> — Leases for incubator spaces are short term and flexible (easy in/ out conditions). If the business succeeds it might move to more traditional accommodation. — Incubators can be part of a larger property offering (e.g. like managed office). ii. Accelerator space: <ul style="list-style-type: none"> — Like incubator space, providers will typically require equity in a business in exchange for the provision of space and access business support services managers. — Accelerators provide occupants with business support for a limited time (typically up to twelve months) and the space is generally provided by licence instead of a formal lease contract. iii. Co-working space: <ul style="list-style-type: none"> — Co-working accommodation typically offers some flexibility in terms of working hours and occupancy terms (different types of memberships). The space often allows for drop-ins, visitors and networking events. 	<p>For IACs:</p> <ul style="list-style-type: none"> — Management should allow flexible, affordable workspace costs (usually provided on a sliding scale of memberships or rental rates) — Providers report a desirable minimum space of 743m² (8,000sq.ft) to provide co-working spaces.
	Shared facilities	<p>For IACs:</p> <ul style="list-style-type: none"> — Shared facilities including equipment which ensures that the cost of occupying space is lower than for market rate office space. Desks in co-working facilities offer access to workstations, computers, phones, power and broadband connectivity. 	<p>For managed workspace:</p> <ul style="list-style-type: none"> — Potential for shared facilities including meeting rooms, kitchen, WCs. <p>For IACs:</p> <ul style="list-style-type: none"> — Most critical factors aiding in business start-up and growth relate to non-spatial factors e.g.: affordability and access to business support, shared resources and collaboration opportunities.

Page intentionally blank

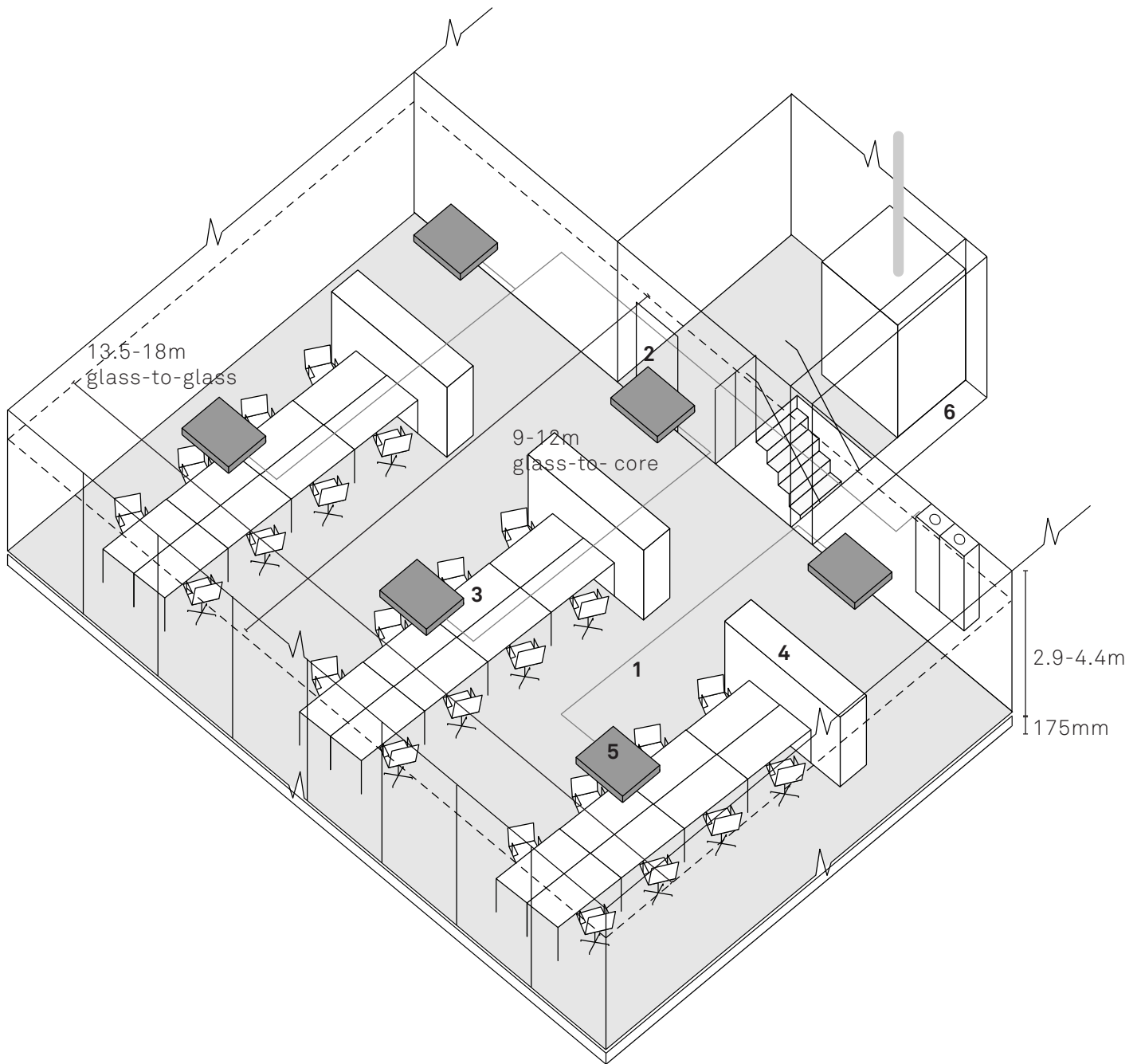

Key:
Large Office Space Provision

- 1. Greater than 500m² floor area
- 2. Unit-specific entrance
- 3. Desk-based working
- 4. Storage
- 5. Ducted ventilation system/ VRF where passive ventilation not possible
- 6. Service riser 2% of floor area

Sub-type components

- 2.2 Managed workspace: As per Typology 1.0, plus shared facilities
- 2.3 IAC space: Likely open plan, potentially lower specification (visible servicing) plus shared facilities

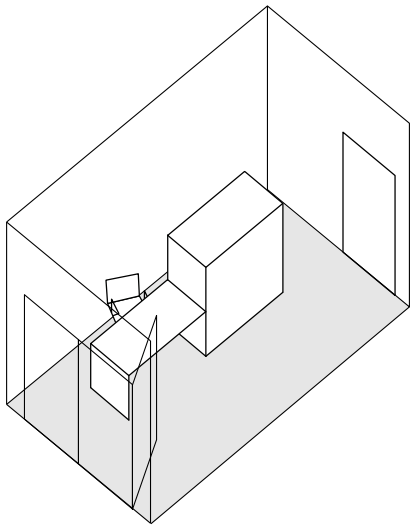

Reception (possibly street-facing)

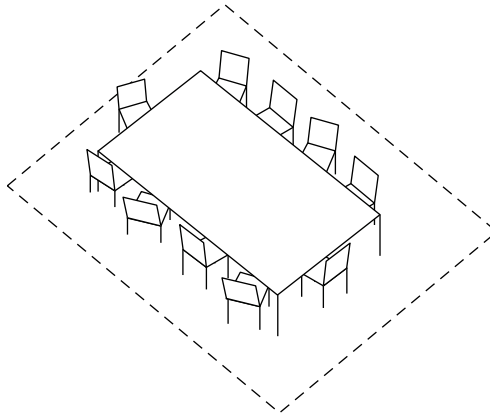

Meeting room(s)

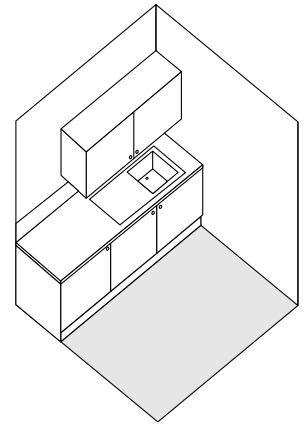

Kitchenette

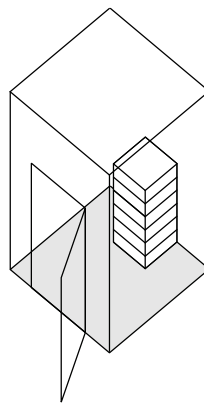

Communications room (2x2m space per 500m² floor area)

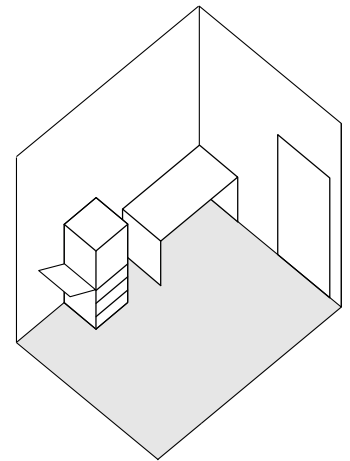

Print room/ area

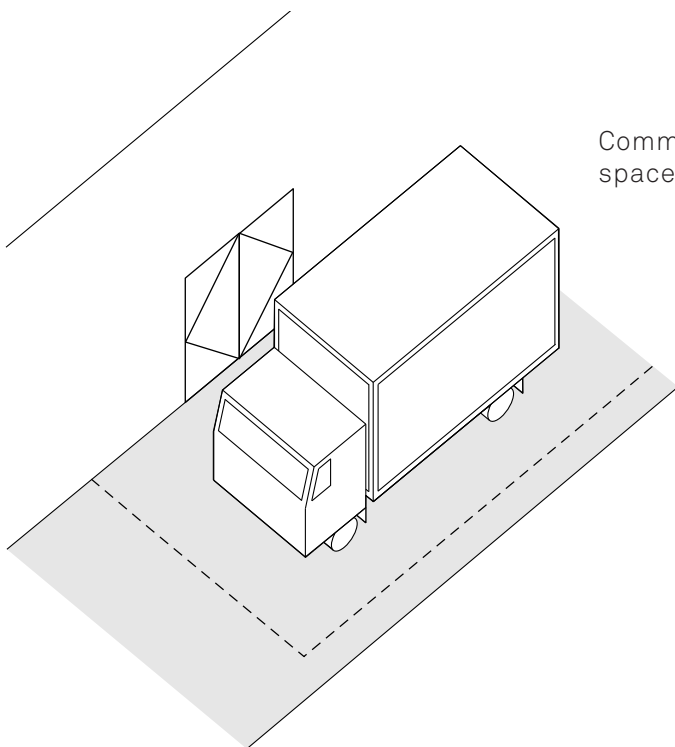

Dedicated delivery bay

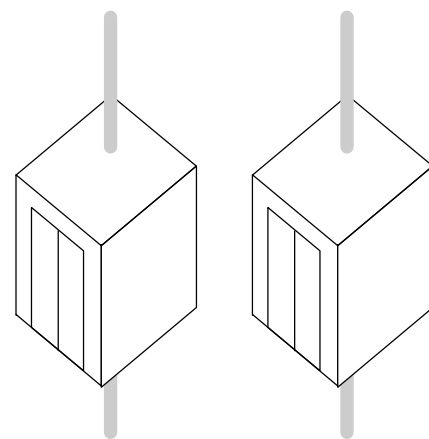

Separate passenger & goods lifts

Large Office Space Typical Components

3.0 STUDIO TYPE SPACE



Stour Space Creative Hub, Roach Road

Introduction

This typology spans workspace for creative uses that may have additional spatial requirements above and beyond those of office-type work places. Despite these spatial requirements, the activities are within 'B1 B, Research and development of products or processes)' or 'B1 C, Light industry)' planning use classes.

Typology Characteristics

- Lower ceiling (2.9-4-4m), but with higher preferred minimum (3.5m)
- Provision on any floor
- Require occasional servicing / deliveries related to production materials, which may be of a large scale
- Generally minimally disruptive, low-noise level neighbours

Target Markets

- Creative industries (including non-commercial activities- i.e. artists, performing arts, craft, publishing, music)
- Creative services (film and media production, photography services etc)

Typical Use Class

B1b, B1c

Sub-typologies

- 3.1 Small creative studio
- 3.2 Large creative studio

3.1 Small creative studio



As found in LLDC area

- Concentrated provision in Hackney Wick & Fish Island, typically provided in previously industrial or warehousing space, above ground level.

Example Scheme: Great Western Studios

Great Western Studios is a new build 5,574m² (60,000sq.ft) facility providing 106 affordable studios spaces to a variety of creative enterprises, including designers, makers, artists, fashion designers and TV production companies. The studios were built on the site of a disused former paint factory in the Westbourne ward of Westminster, having been relocated from a previous premises affected by Crossrail development.

Westminster City Council were instrumental in enabling Great Western Studios to develop by helping to broker the development opportunity with landowners, London Underground, providing a £3m loan on commercial terms and offering conditional grant funding of £1m. The total development costs for the Studios were approximately £9m, with the remainder being privately funded.

Key Features

- Generally small scale, cellular spaces around 10m² (105sq.ft).
- Larger scale efficient buildings allow for critical mass and keep rents/running costs as low as possible.
- Tenants are likely to be highly price sensitive.
- Can be provided by dedicated artist studio workspace management.
- Providers report an ideal minimum of 450m² (5,000 sq.ft).

Typical Uses

- Artist studios
- Creative sector services
- Small-scale makers

Terms of the Council grant funding were that 2,137m² (23,000sq.ft) of the available workspace be let at 50% of market rental values for 10 years. It has thus enabled a large number of micro and early stage creative businesses to locate and grow within the facility. The WCC loan has now been paid off in full and the Studios are 100% let and profit-making, requiring no ongoing local authority support.

3.2 Large creative studio



Example Scheme: Live Stock Market, Hackney Wick

Live Stock Market is an art production company created primarily to manage artist Gavin Turk's studio. Gavin Turk is a British-born, international artist. The building is a large industrial warehouse, of 280m² (3,000 sq.ft) total floor area. It was previously a reproduction furniture factory, then a garage.

Due to the varied nature of the work undertaken by the studio, work has been undertaken to divide the spaces creating: a screen printing room, spraying room, kitchen, office, workshop and storage. Some spaces have multiple functions, such as the workshop also being used for photography. The presence of a messy areas, clean areas/ offices and storage are all essential.

Key Features

- Large space, which accommodates a range of creative production activities.
- Larger scale efficient buildings allow for flexible uses, including desk-based work as well as spaces for production.

Typical Uses

- Artist studios (working with assistants).
- Creative sector services, especially media and broadcasting (film-making, photography).

As found in LLDC area

- Large floorspaces in previously industrial or warehousing spaces, provided at both ground level or above, depending on the production activities of the tenants.

Page intentionally blank

STUDIO TYPE SPACE			
	Attribute	Typology Specification	
		Standard	Ideal
Dimensions	Range of floor area per unit	For small creative studio: <ul style="list-style-type: none"> — Individual studios range from 11- 32m²(118-344sq.ft) For large creative studio: <ul style="list-style-type: none"> — Individual studios range from 32-500m²(344-5,382sq.ft) 	<ul style="list-style-type: none"> — Tenants have a variety of spatial needs. For small creative studio: <ul style="list-style-type: none"> — Generally a minimum of 15 studios required to create a critical mass
	Floor to ceiling heights (internal dimensions)	<ul style="list-style-type: none"> — 2.9 -4.4m ceiling height. — Generally a minimum ceiling height of 3.5m is preferred. 	<ul style="list-style-type: none"> — Increased height has a value in terms of stacked storage and wall space and taller ceiling allows deeper penetration of daylight.
	Provision possible on which floor	<ul style="list-style-type: none"> — Can be provided at street-level or within building at any floor. — Generally spaces are better located off the street but some occupiers would benefit from being located with a presence on the public realm. For large creative studios: <ul style="list-style-type: none"> — Due to loading and access requirements, large studios are better suited to ground floor provision. 	
Access & Servicing	Entrance arrangements	<ul style="list-style-type: none"> — Occupier access should be secure, with possibility to individually lock studios or a safe within each studio. — Need for staffing / client access as well as some requirements for materials to be brought into studio spaces. 	
	Servicing	<ul style="list-style-type: none"> — Utility provision is dependent upon the scope of offering. — Standard inclusion covers: small power, lighting, emergency lighting, fire and smoke detection, security systems for perimeter and studios, internet access and comms, water — Metering and sub metering for individual tenants. — Heating of spaces either through a wet system (boiler and radiators) or space heaters. 	<ul style="list-style-type: none"> — Specialist provision may include: Gas for heating and creative equipment zones (firing kilns), 3 phase power for creative equipment zones (welding). — Provision of additional services access points can allow sub-division of larger spaces.
	Vehicle access	<ul style="list-style-type: none"> — Some operational parking required for moving of materials within studio. — Provide a dedicated loading/ unloading access to the building with enough space for a rigid HGV circulation — Vehicle and cycle parking provided in line with The London Plan. 	<ul style="list-style-type: none"> — Additional cycle parking may be desirable to encourage tenants to consider sustainable transport methods.

STUDIO TYPE SPACE			
	Attribute	Typology Specification	
		Standard	Ideal
Access & Servicing	Waste management	<ul style="list-style-type: none"> — Need to accommodate and situate appropriate internal / external capacity and accessibility for all waste that is generated. Special consideration may need to be given for the less typical types of waste generated. 	
	Transport connections	<p>For small creative studios:</p> <ul style="list-style-type: none"> — Some need to access to key local transport routes, but not crucial to link to larger regional routes. <p>For large creative studios:</p> <ul style="list-style-type: none"> — Access to key local transport routes and larger regional routes an asset to provision. 	
Environmental Considerations	Noise	<ul style="list-style-type: none"> — Hours of operation can be outside conventional working hours (24 hour). — Generally low noise-level creative/ making functions, some need for particular sound insulation. — Refer to the Appendix for detailed noise mitigation measures. 	
	Emissions	<ul style="list-style-type: none"> — Potentially disruptive/ noxious emissions associated with making spaces. — Centralised extraction system (including scrubber unit where applicable) for removal of possible solvents etc. 	
Exterior & Interior	Open space/ yard requirements	<ul style="list-style-type: none"> — Communal/break out spaces encourage interaction and foster a creative community but do not generate revenue and have a negative impact on floorspace efficiency. 	<ul style="list-style-type: none"> — External yards can provide opportunities for making of over-sized works, where available.

STUDIO TYPE SPACE			
	Attribute	Typology Specification	
		Standard	Ideal
Exterior & Interior	Quality of internal environment	<ul style="list-style-type: none"> — Suitable for refurbished spaces – dependent on the nature of activity- production/media businesses will seek higher quality (potentially new) space whilst artists may require lower quality secondhand space which tend to be of lower specification/fit out levels given the nature of activity. — Space that is customisable – activities and therefore space requirements are varied, therefore a ‘standard’ product may not meet needs. — Large, open spaces – most activities require spaces that provide appropriate scale (height and floorplan) to accommodate large equipment or other installations, artist activity will require natural light. — Non-structural dividing walls increase adaptability for tenants with specialist equipment: screen printing presses, workshop areas etc 	<ul style="list-style-type: none"> — Artist studio spaces often benefit from high proportion of wall area . — Ideally the windows reflect the height within the room to maximise light ingress. Preference for a balanced light would be north facing, otherwise for east, south, west orientations, there will be a need for solar shading. — A floor loading between 3.5 – 5kN/ m² to provide flexibility for use. Additionally the ground floor studios can be set aside for heavier floor load requirements greater than above. — Sliding and lockable division walls to enable sub-division of areas. — Many artists prefer private workspaces and as such features like glass -paneled doors are undesirable. — Weak plasterboard walls not considered desirable given heavier hanging requirements of some artists.
	Movement of materials within spaces	<ul style="list-style-type: none"> — Wide corridors are useful for moving work and objects but not too wide to become storage. — Multi-storey studios require a goods lift for vertical material movements and a goods in covered zone / lobby area. — Good sized goods lift and wide corridors are useful for moving work and objects (500-1000kg loading). 	
	Interaction with the street	<ul style="list-style-type: none"> — Majority of artists prefer studios to be private and not public fronting. — Visibility of common areas and shared facilities more suited to street activation than individual studios. 	

STUDIO TYPE SPACE			
	Attribute	Typology Specification	
		Standard	Ideal
Other	Management & tenure	<ul style="list-style-type: none"> — The management arrangements for providers of studio type space are similar to managed workspace although the model for delivering the provision of space can be different. Whereas managed workspace is typically provided by for-profit organisations (but also charities or trusts), the economic challenge of providing affordable studio space for artistic activity means that a degree of subsidy is typically required as part of the business model. — Nearly half of the studio providers in London operate their organisations wholly or partially as charities. — In some cases, the providers are hybrid organisations consisting of a charity and limited company. Despite the variety of providers, the relationship between provider and tenant is relatively straightforward. — Licenses and lease lengths vary from six months to 10 years for occupancy of a discrete unit. The variety of lease length reflects to some extent the artists' preference/capacity to pay. — Some facilities provide co-working/drop-in space and shared facilities (e.g., print making) for occupants who don't want to have their own unit. <p>For small creative studios:</p> <ul style="list-style-type: none"> — Let as individual desk space or workspace — Can be provided by dedicated artist studio workspace management . <p>For large creative studios:</p> <ul style="list-style-type: none"> — Let by owner usually on longer term basis. There are no particular management arrangements. 	<ul style="list-style-type: none"> — Leasing agreement generally more flexible or short-term than conventional office space or managed workspace — Providers report that shared communal spaces are less valuable for studio provision and these spaces are often sacrificed to provide more studio space.

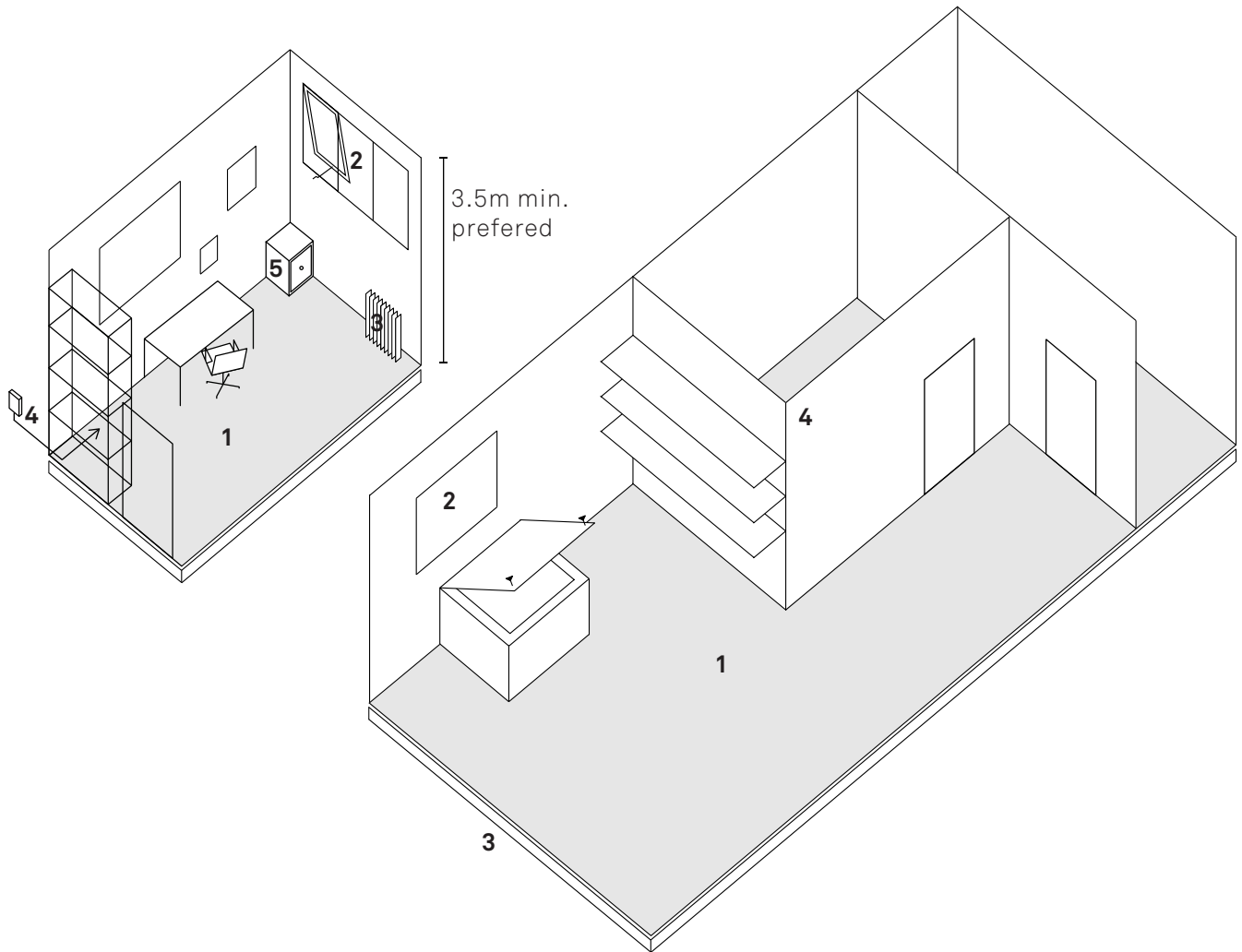

**Key:
Small Creative Studio Provision**

1. 11-32m² floor area
2. Windows reflect height of space to maximise lighting
3. Heating through wet system or space heaters
4. Potential for sub-metered servicing
5. Safe or locking door

Note: Long-narrow spaces maximising useable wall space are desirable.

**Key:
Large Creative Studio Provision**

1. 32-500m² floor area
2. Windows reflect height of space to maximise lighting
3. Floor loading between 3.5-5kN/m²
4. Slidable/non-loadbearing division walls to enable subdivision

Note: Larger studios likely to be sub-divided into clean and 'messy' spaces. Flexibility for specific sub-division is essential.

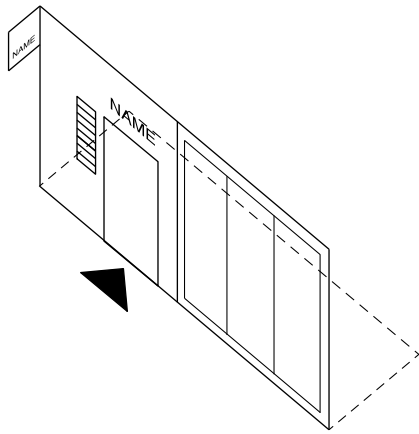

Street facing entrance
(common areas more suited to street activation than individual studios)

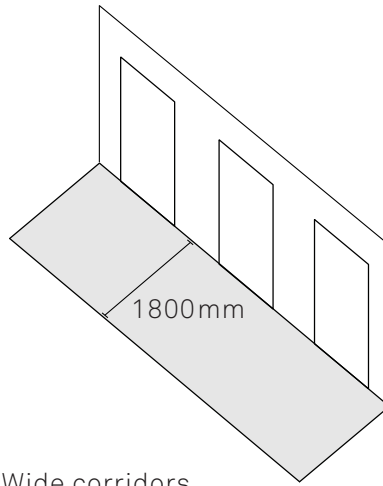

Wide corridors

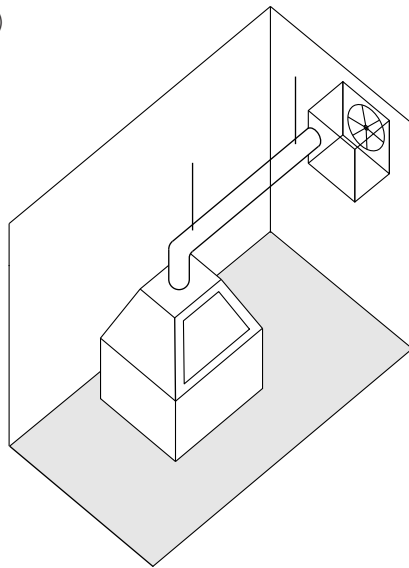

Localised extract e.g. fume cupboard

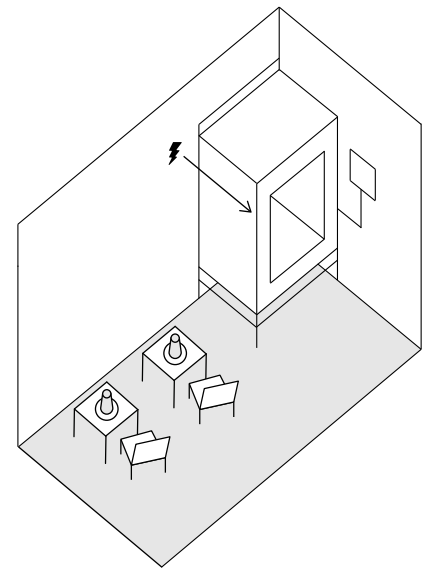

Specialist equipment may require 3 phase power, e.g. ceramics studio/ kiln

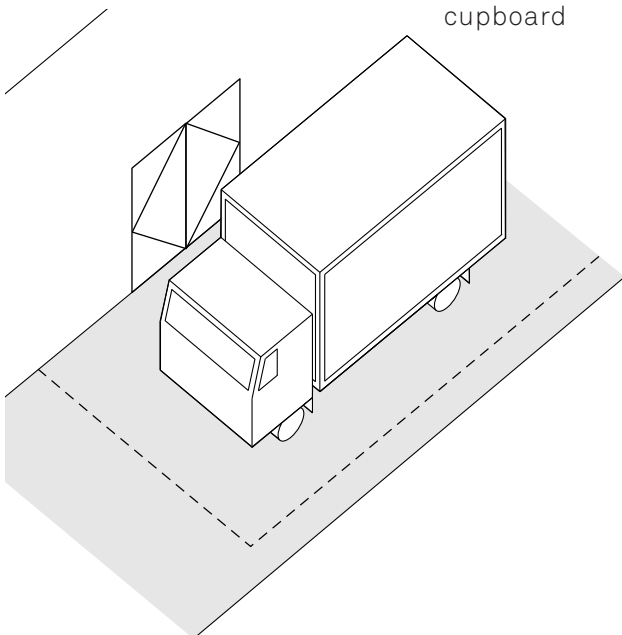

Designated delivery bay

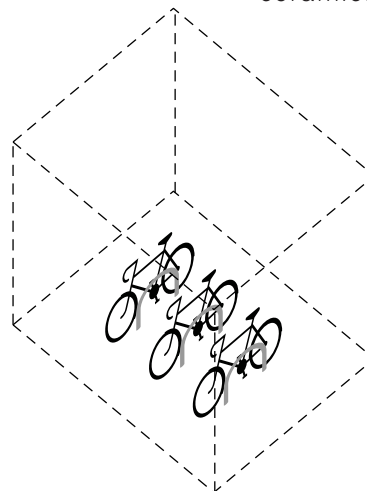

Secure Cycle Storage

Creative Studio Typical Components

4.0 SMALL INDUSTRIAL / WAREHOUSE TYPE SPACE



E. Abrahams, Fine Art & Packing Cases, Wick Lane

Introduction

This typology covers small scale industrial uses. By their nature, these uses have greater spatial requirements than any of the previously described categories, are likely to require servicing by large goods vehicles and may have specific servicing requirements such as three-phase power and mechanical extract equipment.

Typology Characteristics

- 500m^2 (5,382sq.ft)
- Higher ceiling (4.5 - 8m)
- 4m loading bay
- Purpose-built shed/ unit

Target Markets

- Small scale making and light manufacturing

- Secondary/ tertiary industry such as printing, textiles etc
- Small to medium food & drink manufacturing
- 'Industrial crafts' and small scale manufacturing
- Open access specialist fabrication

Typical Use Class

B2, B8

Sub-types

- 4.1 Small industrial space
- 4.2 Maker space

4.1 Small industrial space



Example Scheme: Truman Brewery, Hackney Wick

This example occupies a typical purpose-built industrial unit. The business occupies 460m² (5,000sq.ft) internally, spread between two adjacent units of the same size. Of the available floorspace, 50% is used for brewing, 30-40% cold storage and the remainder for administration, dry storage, events etc. Ceiling heights in the building range from 4.6m to 5.4m at the height of the roof pitch. The contiguous nature of the units within the building has allowed the business to expand into adjacent units as they have grown.

A yard space of equal size to the internal spaces is used for cask washing, storing spent grain, parking and articulated vehicle access.

Key Features

- Smaller-scale units for light industrial uses.
- Leased as individual units to single tenants, usually on longer-term leases.

Typical Uses

- Advanced manufacturing
- Small-scale storage & wholesale
- Food & drink manufacturing

As found in LLDC area

- Strong presence across the LLDC area. Often provided with associated yard space for production and delivery operations and with ancillary spaces for office / administration use.

4.2 Maker Space



Key Features

- Leasing arrangements vary from leasing individual workshop spaces, to drop-in open access space to collective leasing of larger workshop spaces.
- Usually short-term / more flexible lease terms.
- Some maker spaces are operated by a workspace provider managing units across a larger space, others are provided individually by landlords.

Typical Uses

- Collaborative/ collective making
- Open access workshops
- Small- to medium scale making
- Small-scale product development

As found in LLDC area

- Increasing presence in the area given available warehouse and industrial stock with larger floorspace and yard spaces suitable for shared making facilities. A key example from the area is Workshop East on Sugarhouse Lane.

Example Scheme: Blackhorse Workshops, Waltham Forest

Blackhorse Workshop is a CIC established in 2013, becoming operational as a public, open access workshop in early 2014. It was developed by architecture and design practice Assemble, in collaboration with artists, businesses and community organisations.

The building had been constructed within the last 10 years and required minimal investment of £80,000 to fit out. It occupies approximately 850m² (9,200sq. ft) over two storeys and has a large external courtyard with lockable gates. Construction is brick and blockwork to ground floor, with insulated aluminium panels to the upper storeys. The building has two large double roller shutter entrance doors providing good delivery access and storage. It has reinforced concrete floors ideal for heavier workshop equipment³

3 'Co-Making: Research into London's Open Access Makerspaces and Shared Workshops', Workshop East

Page intentionally blank

SMALL INDUSTRIAL / WAREHOUSE TYPE SPACE			
	Attribute	Typology Specification	
		Standard	Ideal
Dimensions	Range of floor area per unit	<ul style="list-style-type: none"> Individual units <500m² (5,382sq.ft) For maker spaces: <ul style="list-style-type: none"> Individual units typically 150-200m² (1,615-2,153sq.ft), with larger floorspace usually occupied by larger organisations - open access or educational uses 	
	Floor to ceiling heights (internal dimensions)	<ul style="list-style-type: none"> Higher ceiling (4.5 - 8m), generally minimum 4m ceiling height. Double height spaces (min. 6m) allow for smaller scale elements to be stacked around taller spaces and / or for production areas where lifting / handling may be required. Provides adequate flexibility for adapting mezzanine office fit-out for 10% of space 	<ul style="list-style-type: none"> 2.9m ideal minimum height for mezzanine office space provision. For small industrial spaces: <ul style="list-style-type: none"> For intensive manufacture, high stacking, overhead hoists or mezzanine floors a minimum height of 7.5 m recommended.
	Provision possible on which floor	<ul style="list-style-type: none"> Best provided at street-level to allow for ease of servicing, delivery of materials, access to outdoor production spaces. 	
Access & Servicing	Entrance arrangements	<ul style="list-style-type: none"> Some need for large entry access points for vehicles transporting materials and for regular servicing. Openings should be large enough for delivery of goods and equipment: roll-up doors with minimum height of 3.7m and width of 2.4-3m 	<ul style="list-style-type: none"> Openings associated with a loading bay to be 5m high.
	Servicing	<ul style="list-style-type: none"> Energy efficient heating system expected by tenants. For work areas, electrical system (dry option) - Radiant Panel / Blown Air - Lower installation costs / expensive running costs. Gas / Oil Fuel (wet system) - Radiant / Blown Air - Higher installation costs / lower running cost. Internally 18-21 deg C achieved, avoiding overheating in summer- air-change rate (fresh air supply) minimum 5 l/s/person For office/ancillary space, dry electrical unit space heating, with point of use water heating, where wet fired system not implemented. Drainage pipes away from floor areas. 3-phase power 	<ul style="list-style-type: none"> Wet fired heating system providing space and water heating to ancillary areas - offices / lavatories / etc. and work areas. Facility to take any production service (water, steam, gas, electrical power, etc.) to any point within production area with minimum disturbance to building, and therefore production.

SMALL INDUSTRIAL / WAREHOUSE TYPE SPACE			
	Attribute	Typology Specification	
		Standard	Ideal
Access & Servicing	Vehicle access	<ul style="list-style-type: none"> For regular deliveries, unit should accommodate light / medium vehicle access up to 7.5 ton, with occasional HGV access. 	<ul style="list-style-type: none"> Loading facilities integrated to indoor areas where practicable. Side loading scenarios should be considered.
	Waste management	<ul style="list-style-type: none"> Need to accommodate and situate appropriate external capacity and accessibility for all waste that is generated by the full range of potential occupants. 	
	Transport connections		<ul style="list-style-type: none"> Benefits from access to key local and regional transport routes to facilitate deliveries and regional customer access.
Environmental Considerations	Noise	<ul style="list-style-type: none"> Hours of operation likely to require control due to management/ supervision arrangements. Generally higher noise-level manufacturing / production functions, need for particular sound insulation to satisfy normal planning requirements. Highly insulated windows with baffled vents to provide trickle air supply. Suitable sound attenuation treatment to externally sited chiller units, LEV's etc. Refer to the Appendix for detailed noise mitigation measures. 	<ul style="list-style-type: none"> Key design factors include glazing, doors, ventilation, building orientation, external walls and roof, separating walls, internal walls and floor performance, reverberation controls and room acoustics, external noise acoustics, protection from plant rooms/zones, communal areas. All are mitigated by careful design to minimise flanking sound (direct/ indirect) transmission. Consider obtaining attenuation from planting, canopies, arcades and setting back façades.
	Emissions	<ul style="list-style-type: none"> Filtered extract systems with capability for noxious outputs, with screened noise attenuation treatment. Boundary structures minimum height / specification. Enclose service space within buildings as appropriate. 	<ul style="list-style-type: none"> Flue discharge needs to integrate with other uses.
Exterior & Interior	Open space / yard requirements	<ul style="list-style-type: none"> Yard or loading space is usually required to allow regular servicing and deliveries, as well as some external operations e.g. keg washing and fabrication of out-sized items. 	<ul style="list-style-type: none"> Some occupiers may desire a public facing retail element. This can be provided in yard or street-facing spaces.

SMALL INDUSTRIAL / WAREHOUSE TYPE SPACE			
	Attribute	Typology Specification	
		Standard	Ideal
Exterior & Interior	Quality of internal environment	<ul style="list-style-type: none"> Generally large scale long span spaces are preferred for maximum flexibility. Some occupiers are able to break operation into smaller spaces (e.g. 4 or 5 different processes which can be in smaller spaces). <p>For maker spaces:</p> <ul style="list-style-type: none"> Capacity for work bench and other dedicated workspaces - for businesses to base themselves within the centre and co-working spaces that can be used alongside the equipment. 	<ul style="list-style-type: none"> For load bearing considerations, general loading /lifting areas – 25 – 30kn/m2; point loadings of 36 KN (pallet racking / cages / fork lift truck wheels); and machine tools – 7.5 – 10 Kn/m2 floor loading.
	Movement of materials within spaces	<ul style="list-style-type: none"> Large spanning areas, allowing access and flexibility of operations. Rectangular plan form with ratio of long to short sides between 1 : 1 (minimises internal travel distances where no particular traffic routes are dictated by process) and 3: 1 (with average of 2: 1). 	<ul style="list-style-type: none"> Goods lift and wide corridors (where applicable) required (500-1000kg loading).
	Interaction with the street	<ul style="list-style-type: none"> Beyond delivery needs, industrial uses may require less street frontage, and so could be narrower than other commercial uses. 	<ul style="list-style-type: none"> Ancillary retail elements have the potential to animate the street. Clear signage for individual businesses and navigation of clusters.
Other	Management & tenure	<p>For maker spaces:</p> <ul style="list-style-type: none"> Management arrangements are similar to small studios. Whereas small creative studios will be more oriented towards accommodating creative pursuits, the occupier base of maker space is more diverse and financially self-sustaining. There are a variety of licenses and lease lengths as well as opportunities to be a user of co-working/drop-in space and shared facilities. Usually short-term / more flexible lease terms for individual occupants. <p>For small industrial spaces:</p> <ul style="list-style-type: none"> Let by owner usually on longer term basis. There are no particular management requirements. 	

Page intentionally blank

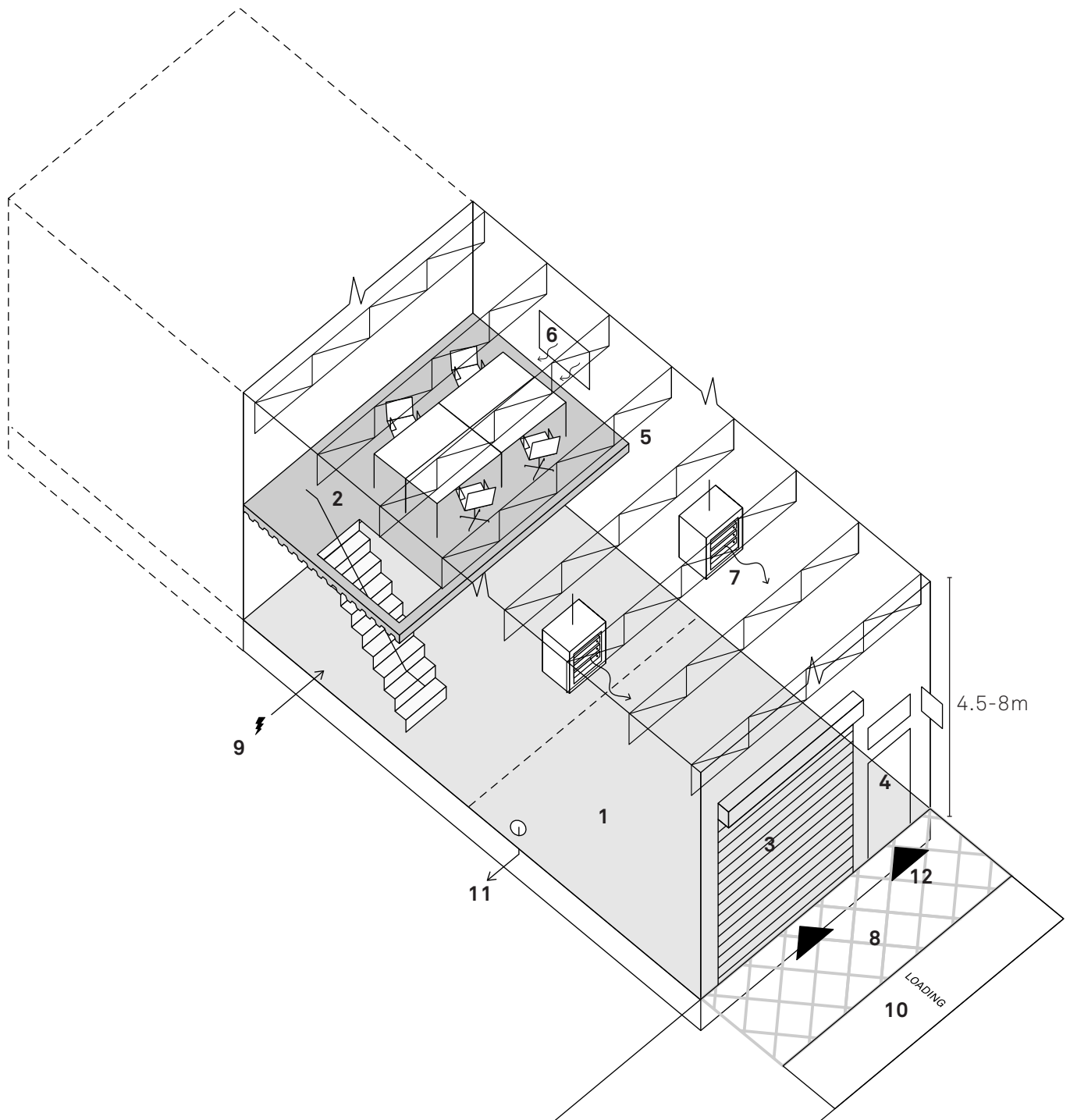

**Key:
Standard Small Industrial Space Provision**

1. Less than 500m² floor area
2. Double height ceiling allows for administration mezzanine. May also be provided adjacent to loading doors in wider units
3. Roller-shuttered doors for deliveries (min. height 3.7m and min. width 2.4-3m)
4. Separate staff/ visitor access with signage
5. Spanning structure creates flexible internal layout
6. Radiator heating to office areas

7. Blow air heating for work areas
8. External loading area
9. 3 phase power
10. 7.5 ton vehicle access and occasional articulated vehicle access
11. Drainage from floor areas (suited to food production/ brewing)
12. Floor loading- refer to table

Note: Typically rectangular plan form with ratio of long to short sides between 1:1 (where no particular traffic routes are dictated by process) and 3:1.

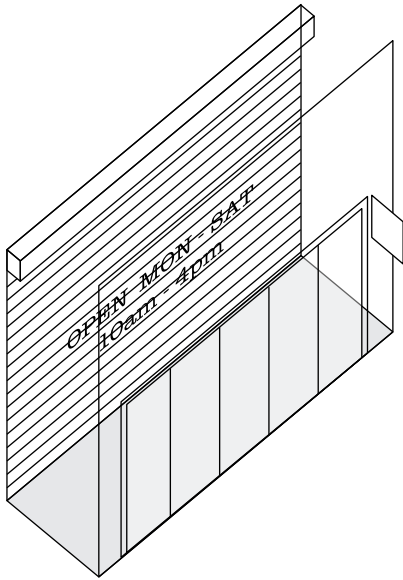

Street-facing entrance/ ancillary retail with signage

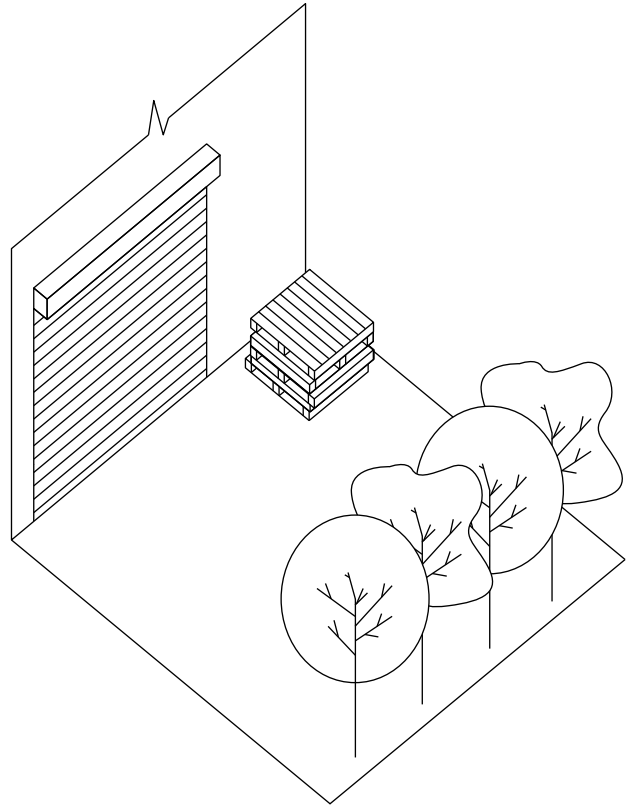

External yard space with environmental screening as appropriate

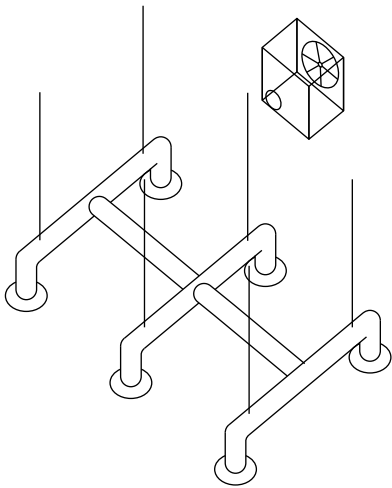

Mechanical extract

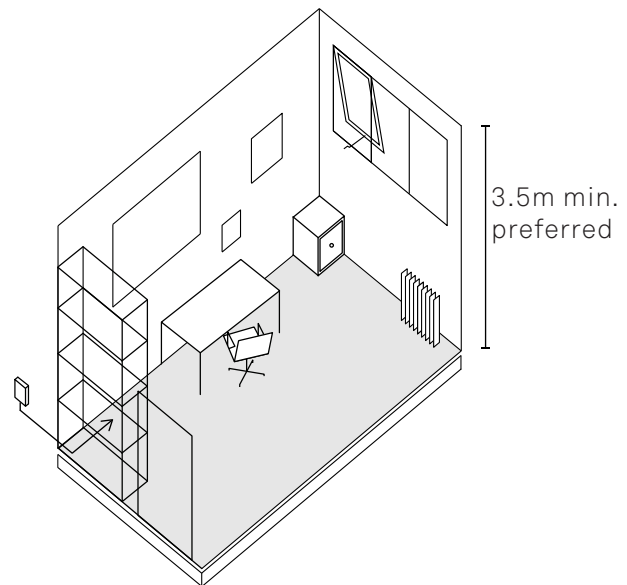

Studio space (typology 3.1), potentially provided in maker space units

Small Industrial Space Optional Components

5.0 LARGE INDUSTRIAL / WAREHOUSE TYPE SPACE



Introduction

This typology represents the largest enclosed workspace volume of all categories. It is characterised by large floorplates and ceiling heights, although these may be sub-divided. Uses are typically noisy and require high levels of large vehicle servicing for deliveries and sales. Combinations of other typologies can also be expected, for example small office-type space in addition to 'shop floors'. Specific uses may necessitate particular servicing requirements such as mechanical extraction.

Typology Characteristics

- >500m² (5,382sq.ft)
- Double height ceiling (6-8m)
- Loading bay
- Purpose-built shed

Target Markets

- Large scale making and heavier manufacturing
- Secondary/ tertiary industry such as printing, textiles etc
- Medium to large food & drink manufacturing
- Large-scale storage providers and large-scale retail (wholesale) operators

Typical Use Class

B2, B8

Sub-types

- 5.1 Large Industrial Space
- 5.2 Wholesale/ Storage Space

5.1 Large industrial space



administrative use and large dedicated delivery spaces.

Example Scheme: Wildspace Warehouse, Rainham

This scheme comprises 3,350m² (36,000sq.ft) of refurbished industrial space. The refurbishment works included: a new insulated roof, bicycle racks, showers, dedicated parking and yard space. The units achieve a BREEAM 'Very Good' rating.

The units have large open spans, structurally reinforced concrete floors, top-lit spaces and the potential for subdivision to create office space within.

Key Features

- Larger-scale units for heavier industrial uses.
- Leased as individual units, usually on longer-term leases.
- Generally 'active' uses, by comparison with Typology 5.1 Wholesale/ Storage Space.

Typical Uses

- General manufacturing
- Advanced manufacturing
- Food & drink manufacturing
- Utilities & waste

As found in LLDC area

- Clusters of larger industrial uses across the LLDC area, often correlated to key transport routes. Typically include office spaces for

5.2 Wholesale / storage space



Example Scheme: Lumina Park, Big Yellow Storage, Enfield

This scheme comprises 5,600m² (60,000sq.ft) of new build self storage facility. Key to the success of such schemes is efficient construction and internal fit out. Despite the 'big shed' appearance, internal subdivisions are likely to be of modest floor-to-ceiling height.

Customer vehicle access and parking, goods lifts and wide internal corridors are all required for successful operation.

Key Features

- Large-scale space with large storage capacities.
- Leased as individual units, usually on longer-term leases.
- Generally few 'active' uses within spaces, with activity focused on vehicular deliveries/collections.

Typical Uses

- Large-scale self-storage facilities
- Wholesale operations

As found in LLDC area

- Clusters of warehouse and storage units across the LLDC area, often correlated to key transport routes. Typically include dedicated parking for customers and large dedicated delivery spaces.

Page intentionally blank

LARGE INDUSTRIAL / WAREHOUSE TYPE SPACE			
	Attribute	Typology Specification	
		Standard	Ideal
Dimensions	Range of floor area per unit	— Individual units >500m ² (5,382sq.ft)	
	Floor to ceiling heights (internal dimensions)	<ul style="list-style-type: none"> — Higher ceiling (6 - 8m), ceiling heights vary depending on occupier and operation. — There should be allowance for 2-storey office facilities within the unit flanking one of the boundary walls. The ground for technical/operational support and first floor for commercial activities. For wholesale/storage space: <ul style="list-style-type: none"> — A lower ceiling height (2.4m) is suitable for the provision of self-storage units, but this is not considered flexible for other large industrial uses. 	— For larger footprint buildings (>1000m ² /10,764sq.ft) the height may increase to 10m – 13m for warehousing operations. This will allow flexibility of operation, from warehousing (8m clear, wide aisle operation) to manufacturing with suitable space for installing lifting equipment such as an overhead crane.
	Provision possible on which floor	— Best provided at street-level to allow for ease of servicing, delivery of materials, access to outdoor production spaces.	
Access & Servicing	Entrance arrangements	<ul style="list-style-type: none"> — Personal car parking will be separate from service yards. Access to industrial offices from the street or car park will not cross the service yard. — There should also be an allowance for a 4m high loading door into the main space. 	— A docking bay may be installed for logistical servicing and other specialist situations.
	Servicing	<ul style="list-style-type: none"> — Mechanical ventilation — Heating: gas supply for heating. Large spaces can be heated via space heating units, hung at high level or floor mounted. LPG (Liquid petroleum gas) heating as alternative - site storage tank will be required. Offices heated through either a wet system (radiators) or electric heating. Offices should be 20°C, working zones 16°C and storage at 13°C. — Power: 3-phase, small power, high bay lighting, office lighting and emergency lighting. Fire alarm, security alarm, data and comms, metering. — Water: Potable water for amenities, min 1Bar at boundary which may need locally boosting. 	— There may be the need for the installation of a fire suppression sprinkler system which will entail a large external water storage tank.

LARGE INDUSTRIAL / WAREHOUSE TYPE SPACE			
	Attribute	Typology Specification	
		Standard	Ideal
Access & Servicing	Vehicle access	<ul style="list-style-type: none"> On-street loading bays are suitable where servicing is not regular but inadequate where there are multiple deliveries each day. There should also be an allowance for a 4m high loading door into the main space. Fixed wheel lorry turning circles will be 13m and approach routes should allow a clear minimum height of 5.03m. The turning circle in the goods yard for an HGV is minimum 26m. 	<ul style="list-style-type: none"> Larger uses may benefit from loading docks. If docking bays are used then there should be a 15.0m allowance for a static HGV backed up to the dock. Additionally a further 10m should be provided for the HGV manoeuvring. The goods yard and car parking should be drained through a petrol interceptor.
	Waste management	<ul style="list-style-type: none"> Need to accommodate and situate appropriate capacity and accessibility for all waste that is generated by the full range of potential occupants. It may be appropriate to consider compaction systems. 	
	Transport connections		<ul style="list-style-type: none"> Benefits from access to key local and regional transport routes to facilitate deliveries and regional customer access.
Environmental Considerations	Noise	<ul style="list-style-type: none"> Hours of operation can be outside of conventional working hours. Planning legislation generally specifies a maximum of 65dB at the site boundary. Externally fixed floor mounted mechanical equipment should be screened or housed within an acoustic shell or with acoustic louvred structure. Refer to the Appendix for detailed noise mitigation measures. 	<ul style="list-style-type: none"> If there are operations within the industrial unit that are excessive in noise, they can be treated locally within the unit.
	Emissions	<ul style="list-style-type: none"> Emissions should be compliant with the Environmental Agency document; H1 Annex F – Air Emissions. In a majority of cases there will be no emissions causing air quality issues relating to general use. 	<ul style="list-style-type: none"> For special cases, there will be need for either an LEV (local extract ventilation) system or a mechanical scrubber unit for removing pollutants or irritants from the air.

LARGE INDUSTRIAL / WAREHOUSE TYPE SPACE			
	Attribute	Typology Specification	
		Standard	Ideal
Exterior & Interior	Open space / yard requirements	<ul style="list-style-type: none"> Yard space requirements likely to be determined by vehicle sizes. Refer to 'Vehicle Access' above 	
	Quality of internal environment	<ul style="list-style-type: none"> Encourage high glazing, glazed roll-up doors, and skylights through podium (where courtyards occur above) to allow light through depth of ground level. For industrial floors in general, a uniformly distributed load of 30kN/m² is acceptable for general operations such as a workshop, low level racking, for industrial units up to 8.0m. Mezzanine levels are generally designed on 3.5kN/m². Service yards are generally designed on 20kN/m². 	<ul style="list-style-type: none"> Larger units with dense racking should be more specific for the floor loading, generally ranging from 50-60kN/m². Flexibility within industrial units is limited as there is a requirement for toilet facilities, M&E services, separate metering of services, external service yards for each unit. However, it is feasible to provide larger units for sub-dividing with suitable service connection points that will enable easy connection should the units be split.
	Movement of materials within spaces	<ul style="list-style-type: none"> Within industrial units, movement of materials will be defined by safe working operations with clear definition between work spaces and material transfer zones. Mode of moving materials such as a fork lift truck has suitable level space for operation. Internal to external movements to be by a smooth operational floor, be it level or a ramp. 	
	Interaction with the street	<ul style="list-style-type: none"> Beyond delivery needs, industrial uses require minimal street frontage. 	
Other	Management & tenure	<ul style="list-style-type: none"> Large industrial space - Let by owner usually on longer term basis. There are no particular management arrangements. Wholesale / Storage space - Let by owner usually on longer term basis. There are no particular management arrangements. 	

Page intentionally blank

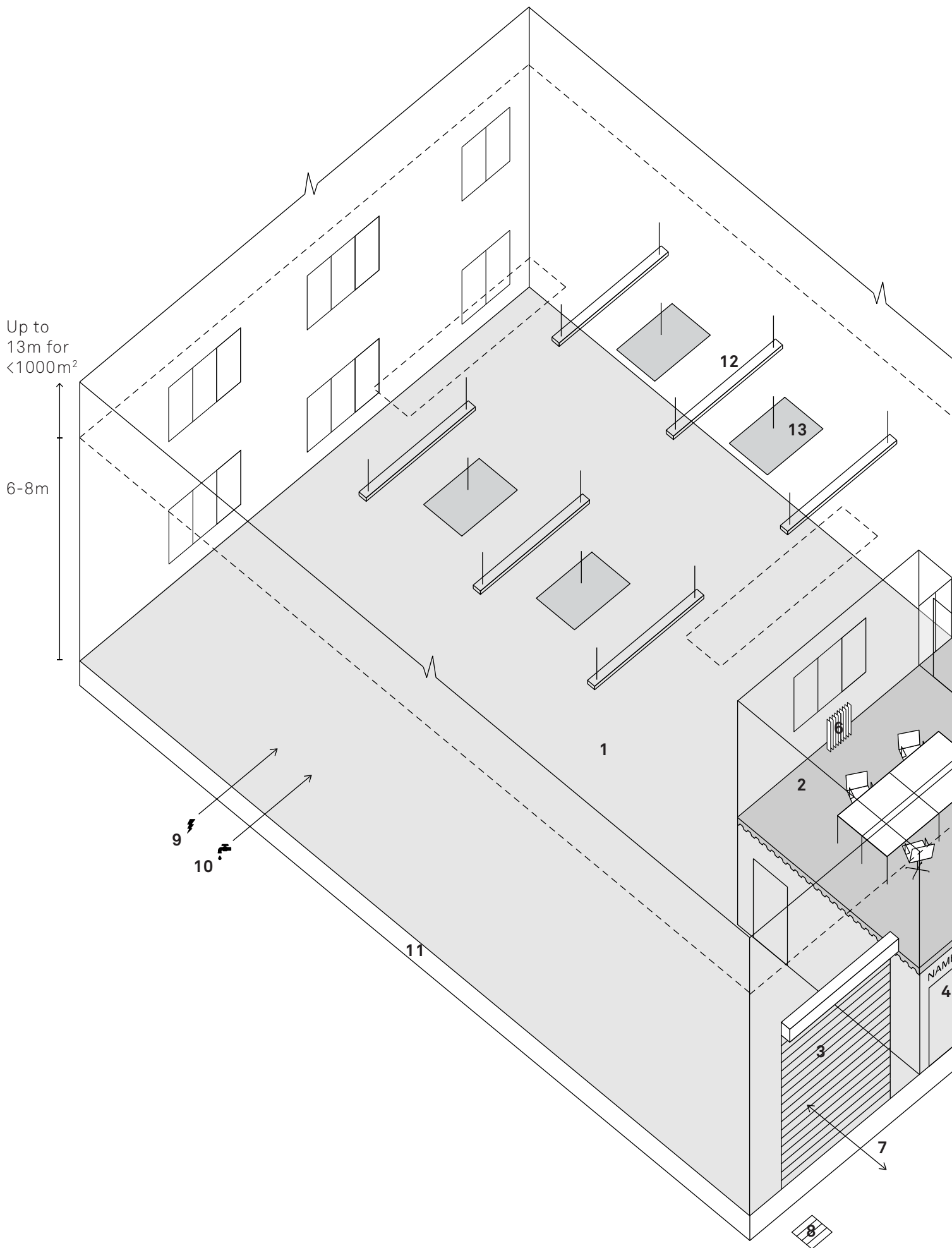

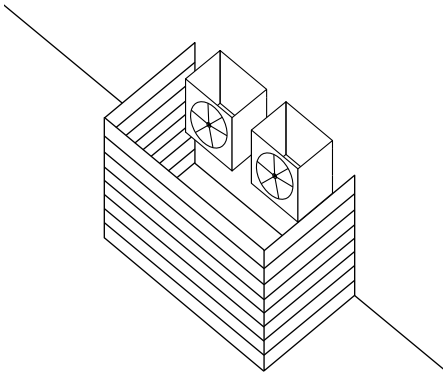

Externally fixed, floor-mounted equipment screened/ housed with acoustic shell

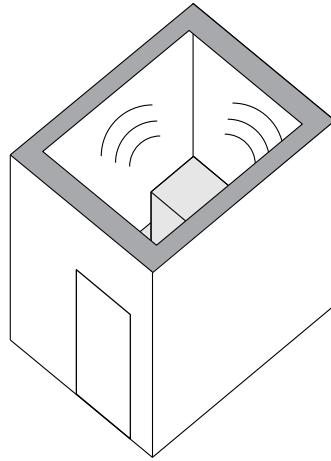

Local acoustic treatment for noisy operations

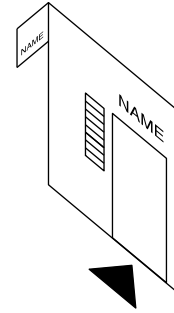

Consider signage for street-facing units

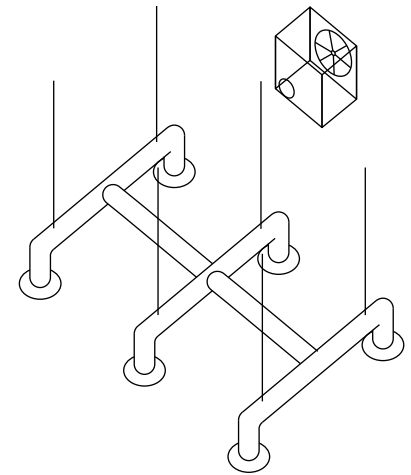
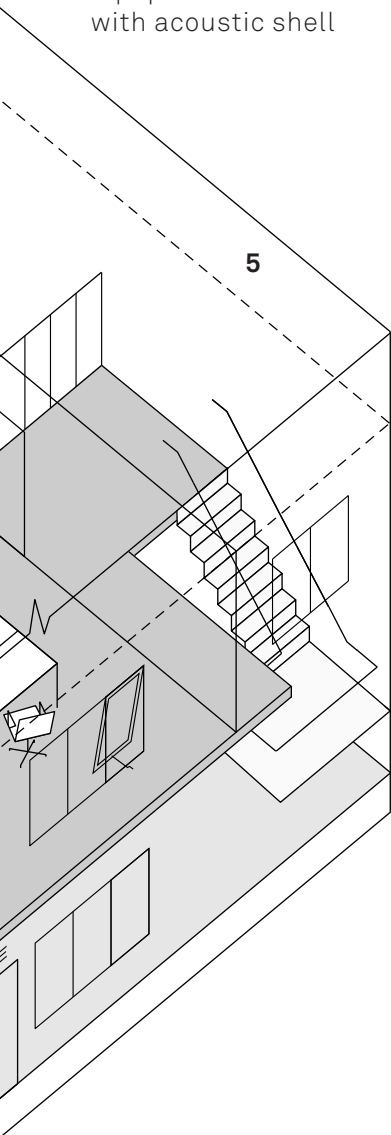

Mechanical extract

Key:

Standard Large Industrial Space Provision

1. Greater than 500m² floor area
2. Double height ceiling allows for administration mezzanine. May also be provided adjacent to loading doors in wider units
3. Roller-shuttered doors for deliveries (min. height 4m)
4. Separate staff/ visitor access with signage
5. Spanning structure creates flexible internal layout
6. Radiator heating to office areas
7. Smooth surface for internal to external movements
8. Petrol interceptor for drainage
9. 3 phase power
10. Water supply with min. 1Bar at boundary, with local boosting possible
11. Floor loading- refer to table
12. High bay lighting
13. Radiant heating panels

Note: External spaces should allow a min. of 15m for local bay and a clear min. height of 5.03m for approach routes

6.0

YARD TYPE SPACE



P.A. Finlay Contractors Yard, Carpenter's Lane

Introduction

This typology provides outdoor workspace for production or service delivery. As a typology, the yard space does not require provision of an associated building, although one may be provided in some instances for administration and staff welfare. Yard spaces are typically associated with storage of goods and materials and may require frequent vehicle access/ manoeuvring for transporting materials from place to place.

— Waste and storage operations (e.g.. scrap yard)

Typical Use Class

B8, Sui generis

Sub Types

6.1 Business Yard

Typology Characteristics

— Yard with no or only small building

Target Markets

- Service-providers (e.g.. vehicle repairs)
- Construction operations

6.1

Business Yard



in the LLDC area typically relate to vehicle maintenance services or equipment repairs and typically occupy smaller 'left-over' sites.

Example Scheme: Balaaj Auto Spares, Rothbury Road

This business provides spare vehicle parts and repair services. The business is highly visible and easily accessible to customers. Although primarily yard space, there is also limited 'sheltered' workspace provided by larger scaffolding structures within the yard space.

Key Features

- Medium- to large-scale outdoor space.
- Leased as individual units, may be shared between adjacent occupiers.

Typical Uses

- Storage and production operations
- Vehicle repairs/ servicing
- Sale & delivery of large scale household goods
- Construction

As found in LLDC area

- Numerous business yard spaces found as part of the area's industrial and manufacturing legacy, typically used to store production or construction materials and as sites for messy production activities. Other yard spaces

YARD TYPE SPACE			
	Attribute	Typology Specification	
		Standard	Ideal
Dimensions	Range of floor area per unit	<ul style="list-style-type: none"> Individual spaces >500m² (5,382sq.ft) Generally large spatial requirements (potentially subdivided across different operations). 	
	Floor to ceiling heights (internal dimensions)	<ul style="list-style-type: none"> N/A 	
	Provision possible on which floor	<ul style="list-style-type: none"> Have to be provided at street-level to allow for ease of servicing, delivery of materials, access to outdoor production spaces. 	
Access & Servicing	Entrance arrangements	<ul style="list-style-type: none"> Will need access/egress width through an entrance to provide 2 way flow where it abuts a main road. Allowance of 8m clear would be acceptable, recessed to enable the traction unit to gain clear vision of traffic. 	
	Servicing	<ul style="list-style-type: none"> Water supply, pressure 1 bar at the boundary. Capability to offer 3 phase power for work on vehicles. General small power allowance. Petrol interceptor for yard drainage 	
	Vehicle access	<ul style="list-style-type: none"> For deliveries: light / medium vehicle access up to 7.5 ton, side loading scenarios. On-street loading bays are suitable where servicing is not regular but inadequate where there are multiple deliveries each day. Provision of adequate fire appliance access. 	<ul style="list-style-type: none"> If appropriate, staff/visitor parking for small vehicles, well delineated to avoid conflicts with public highway use, down a dedicated access road from suitably sized link road.
	Waste management	<ul style="list-style-type: none"> Need to accommodate and situate appropriate capacity and accessibility for all waste that is generated. Appropriate surfacing should be situated in the collection area. 	
	Transport connections		<ul style="list-style-type: none"> Some need to access to key local transport routes, but not crucial to link to larger regional routes.
Environmental Considerations	Noise	<ul style="list-style-type: none"> Potentially disruptive, noisy activities. 65db max. noise at boundary to satisfy normal planning requirements. Boundary structures to provide sound attenuation specification. Refer to the Appendix for detailed noise mitigation measures. 	

YARD TYPE SPACE			
	Attribute	Typology Specification	
		Standard	Ideal
Environmental Considerations	Emissions	<ul style="list-style-type: none"> Aggregate yards may use mist sprays to minimise airborne particulates. Open air nature of yard space makes emissions challenging to control. 	
	Exterior & Interior	Open space / yard requirements	<ul style="list-style-type: none"> Security consistent with Secure by Design - Lighting, Building Form, Hidden areas, etc. seeking local guidance from Police Architectural Liaison Officer. High security boundary fencing, including communal gating, where practicable. Secure, lit, CCTV, alarmed. Maximum controlled heights appropriate to surroundings. Appropriate manageable hardstandings. Building and fire regulations consideration. While the escape distance may not be an issue, the division / spacing of the units will require adequate fire resistance provision.
Quality of internal environment		<ul style="list-style-type: none"> N/A 	
Movement of materials within spaces		<ul style="list-style-type: none"> Considerable requirements to move materials within the yard space, related to production processes, storage, and packing and delivery. Preferable to maintain a majority of activities in the central portion of the yard and using the perimeter for parking, storage. 	
Interaction with the street		<ul style="list-style-type: none"> Generally spaces are better located off the street. Consider street frontage and access of any small shed/office buildings on site for positive street presence. 	
Other	Management & tenure	<ul style="list-style-type: none"> Let by owner usually on longer term basis. There are no particular management arrangements. 	

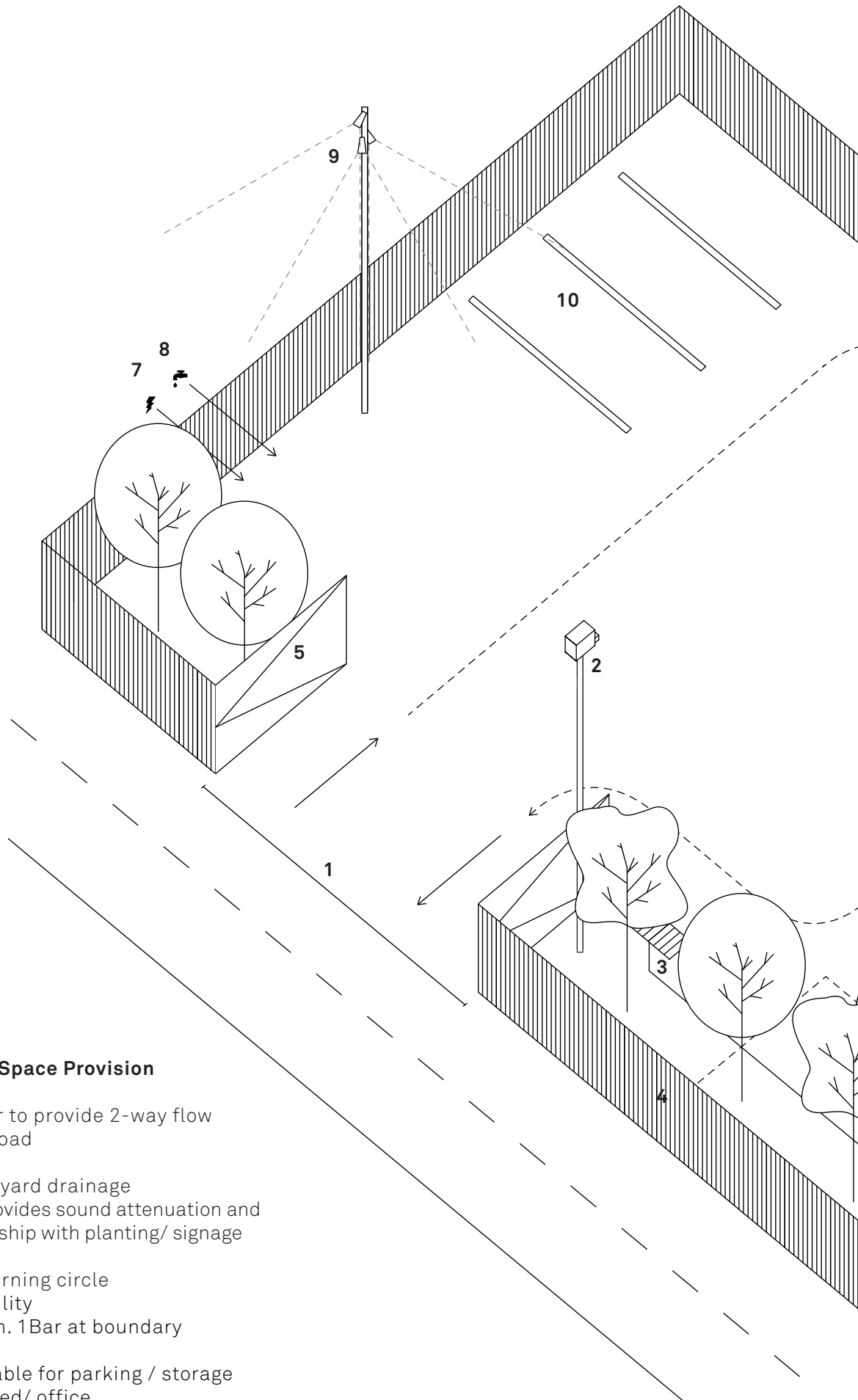

**Key:
Standard Business Yard Space Provision**

1. Allowance of 8m clear to provide 2-way flow when abutting main road
2. CCTV
3. Petrol interceptor for yard drainage
4. Boundary structure provides sound attenuation and positive street relationship with planting/ signage
5. Secure gating
6. Provide for 13-25m turning circle
7. 3 phase power capability
8. Water supply with min. 1Bar at boundary
9. Security lighting
10. Perimeter use preferable for parking / storage
11. Potential for small shed/ office

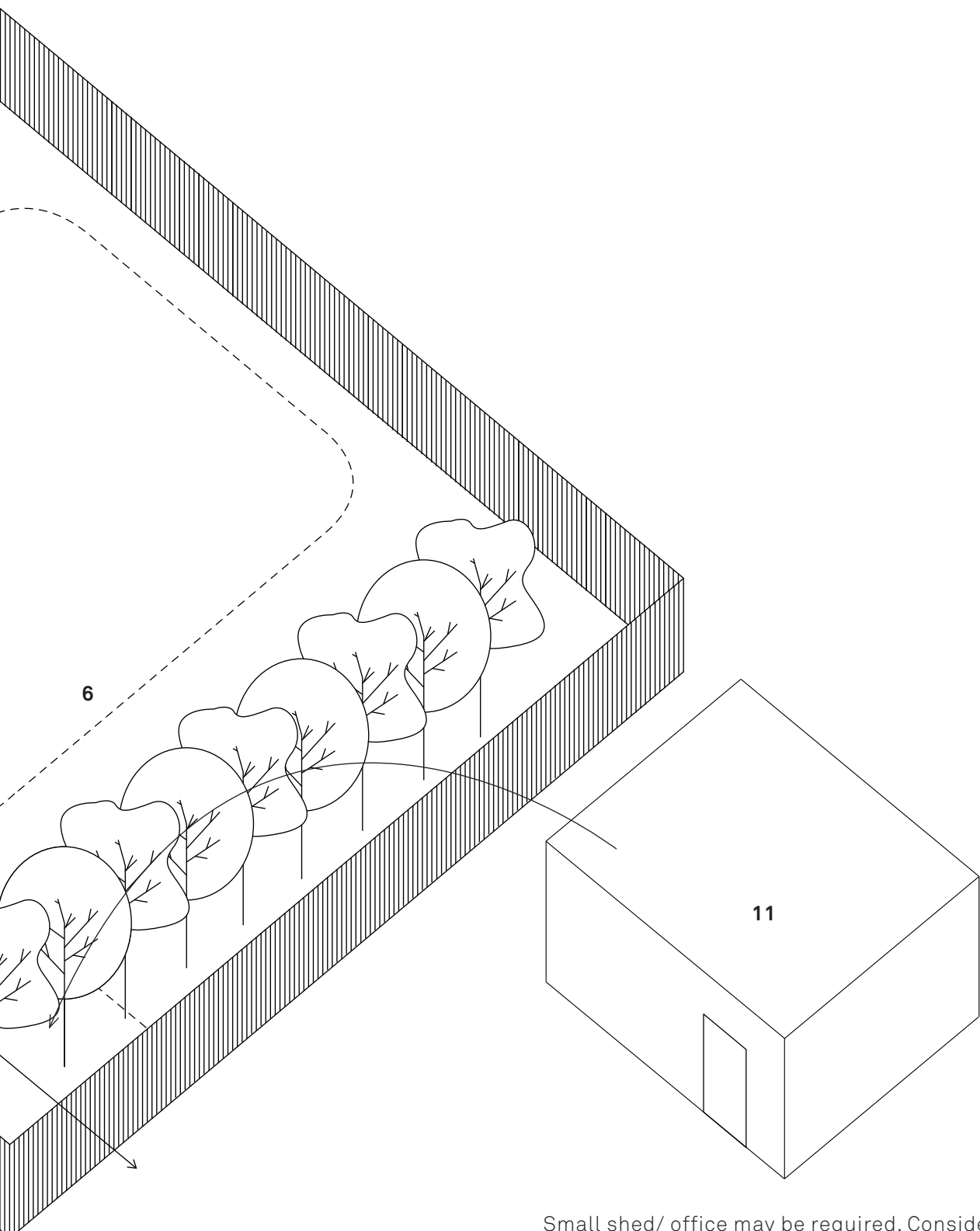

Small shed/ office may be required. Consider street frontage and access for positive street presence.

Page intentionally blank

PART 3:
EMPLOYMENT & MIX



3A

PROVIDING WORKSPACE IN MIXED USE DEVELOPMENTS

The LLDC Local Plan 2015-2031 lays out a strong intention to support the delivery of mixed use neighbourhoods which include high levels of workspace provision. This ambition draws upon the area's existing precedent of a variety of workspace types operating across different neighbourhoods. The Local Plan seeks to encourage the co-location of employment and residential uses where appropriate. This co-location can be understood and delivered both at the level of the individual building as well as at the block level, where different workspace and residential uses are provided adjacent to one another on a neighbourhood block. Further to mixed provision with residential uses, the plan also seeks to explore how existing industrial and commercial areas may be made more productive through densification strategies. This requires supporting the provision of a mix of workspace typologies, again achievable at the scale of both the block and the individual building.

The specifications detailed here aim to provide a guide to workspace standards and user requirements which will result in the provision of suitable, appealing and productive workspaces in the LLDC area. While many recognise the benefits of mixed-use schemes as a concept, workspace provision without an adequate understanding of the needs across different use types can result in workspace which is un-lettable and unsuitable to potential tenants.

The overview matrices below provide a high-level indication of the compatibility of the 6 workspace typologies with a) residential uses, and b) other workspace uses. The matrices indicate the degree of design considerations which accompany different mix configurations. Detailed specifications, industry guidelines and design considerations for the mixed use provision of each typology is provided to address the fine-grain aspects of delivering successful mixed-use developments. These specifications are considered at the block and building scale where design considerations are most instructive.

Conditions for mixed use



Mix at the neighbourhood scale

- Mix at this scale is created through mixing single-use blocks in a neighbourhood area.
- Neighbourhood blocks accommodate single use types (e.g. residential or office space) but these blocks are mixed in order to create a neighbourhood which hosts a number of different uses.
- The city block as the unit to be mixed at this scale.

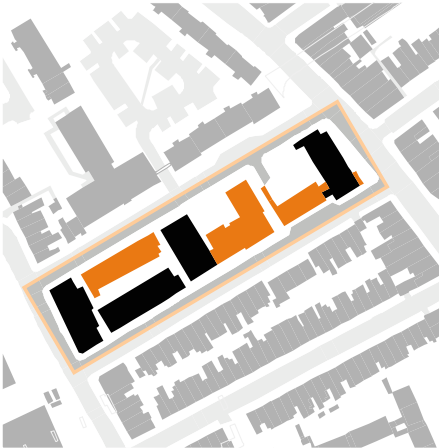

Mix at the block scale

- Mix at this scale is created through mixing single use buildings in a neighbourhood block.
- Individual buildings/plots accommodate single use types (e.g. residential or office space) but these buildings are provided adjacent to each other in order to create a block which hosts a number of different uses.
- The building / plot as the unit to be mixed at this scale.







Mix at the building scale

- Mix at this scale is created through mixing different uses in a single building/plot.
- Different uses (e.g. residential or office space) are mixed horizontally or vertically on a single plot in order to create a building which hosts a number of different uses.
- The workspace is the unit to be mixed

OVERVIEW OF MIX WITH RESIDENTIAL USES

	Mix At Neighbourhood Level	Mix At Block Level	Mix At Building Level
1. Small Office	Block of small office units, easily compatible with neighbouring residential uses.	Building of small office units, easily compatible with residential uses on an adjacent plot.	Individual small office units, easily compatible with residential uses in the same building, both adjacent on the same floor or across different floors, although vertical mix is most common, with office spaces provided on lower floors and residential above.
2. Large Office	Block of large office units, easily compatible with neighbouring residential uses.	Building of office units, easily compatible with residential uses on an adjacent plot, if access requirements are addressed appropriately.	Individual large office units, compatible with residential uses in the same building, if access requirements and shared amenities are addressed appropriately. Vertical mix is most common, with office spaces provided on lower floors and residential above.
3. Studio	Block of studio spaces, compatible with neighbouring residential uses, if access requirements and environmental impacts are addressed appropriately.	Building of studio spaces, compatible with residential uses on an adjacent plot, if access and environmental impacts are addressed appropriately.	Individual studio space units, compatible with residential uses in the same building if access requirements and environmental impacts are addressed appropriately. Studio spaces can be provided at any level provided increased space requirements for the movement of materials is provided for.

KEY





-  Mix possible, with fewer design considerations.
-  Mix possible, with increased design considerations.
-  Mix possible, with considerable design considerations.
-  Mix not possible / not supported.

	Mix At Neighbourhood Level	Mix At Block Level	Mix At Building Level
4. Small Industrial	Block of spaces for small industrial, compatible with neighbouring residential uses, if access requirements and environmental impacts are addressed appropriately.	Building of spaces for small industrial uses, less compatible with residential uses on the same block given access requirements and servicing needs as well as potential environmental impacts. Mix can be less problematic if small industrial uses are not noxious, quieter and don't require regular servicing.	Individual small industrial units, less compatible with residential uses in the same building given accessing and servicing needs as well as potential environmental impacts. Industrial uses will typically be provided on the ground floor. Mix can be less problematic if small industrial uses are not noxious, quieter and don't require regular servicing.
5. Large Industrial	Block of spaces for heavy industrial uses, compatible with neighbouring residential uses, if access requirements and environmental impacts are addressed appropriately.	Building of spaces for heavy industrial uses, less compatible with residential uses on the same block given access requirements and servicing needs as well as potential environmental impacts.	Mix not supported.
6. Yard	Block of yard spaces, less compatible with neighbouring residential uses given access requirements and environmental impacts. Mix can be less problematic if yard space uses are not noxious, quieter and don't require regular servicing.	Individual yard space, less compatible with residential uses on the same block given access requirements and environmental impacts. Mix can be less problematic if yard space uses are not noxious, quieter and don't require regular servicing.	Mix not applicable.

OVERVIEW OF MIX WITH OTHER WORKSPACE USES

	Mix At Neighbourhood Level	Mix At Block Level	Mix At Building Level
1. Small Office	Block of small office units, easily compatible with other neighbouring blocks of studio space, small industrial or other workspaces.	Building of small office units, easily compatible with other workspaces uses in neighbouring plot.	Individual small office units, easily compatible with other workspace uses in the same building. Possible to configure around other office, studio or small industrial space. Unlikely to mix on plot with large industrial uses,
2. Large Office	Block of large office units, easily compatible with neighbouring blocks of studio space, small industrial or other workspaces.	Building of office units, easily compatible with other workspace uses on an adjacent plot, if access requirements are addressed appropriately.	Individual large office units, easily compatible with other workspaces uses in the same building, if access requirements, environmental impacts and shared amenities are addressed appropriately. Offices can be provided on any floor, dependant on the other workspace types included in the building.
3. Studio	Block of studio spaces, easily compatible with neighbouring workspace uses, if access requirements and environmental impacts are addressed appropriately.	Building of studio spaces, easily compatible with workspace uses on an adjacent plot, if access requirements and environmental impacts are addressed appropriately.	Individual studio space units, compatible with other workspace uses in the same building if access requirements and environmental impacts are addressed appropriately. Studio spaces can be provided at any level provided increased space requirements for the movement of materials is provided for.

KEY

-  Mix possible, with fewer design considerations.
-  Mix possible, with increased design considerations.
-  Mix possible, with considerable design considerations.
-  Mix not possible / not supported.

	Mix At Neighbourhood Level	Mix At Block Level	Mix At Building Level
4. Small Industrial	Block of units for light industrial uses, compatible with other workspace uses, if access and environmental impacts are addressed appropriately. Easier to provide into existing workspace areas than into existing residential areas.	Building of units for small industrial uses, compatible with other workspace uses on the same block given accessing and servicing needs as well as potential environmental impacts. Noise attenuation between office/studio spaces and industrial uses required due to shared hours of working.	Individual small industrial units, less compatible with other workspace uses in the same building given accessing and servicing needs as well as potential environmental impacts. Industrial uses will typically be provided on the ground floor. Mix can be less problematic if small industrial uses are not noxious, quieter and don't require regular servicing.
5. Large Industrial	Block of units for heavy industrial uses, compatible with neighbouring workspace uses, if access requirements and environmental impacts are addressed appropriately.	Building of units for heavy industrial uses, less compatible with workspace uses on the same block given access requirements and servicing needs as well as potential environmental impacts.	Individual units for heavy industrial uses, less compatible with other workspace uses in the same building given accessing and servicing needs as well as potential environmental impacts. Industrial uses will typically be provided on the ground floor. Mix can be less problematic if industrial uses are not noxious, quieter and don't require regular servicing.
6. Yard	Block of yard spaces, compatible with neighbouring workspace if access requirements and environmental impacts are addressed appropriately. Mix can be less problematic if yard space uses are not noxious, quieter and don't require regular servicing.	Individual yard space, less compatible with workspace uses on the same block given access requirements and environmental impacts. Mix can be less problematic if yard space uses are not noxious, quieter and don't require regular servicing.	Mix not applicable.

3B

DESIGN CONSIDERATIONS FOR WORKSPACE AND RESIDENTIAL MIX

The following tables describe enhanced levels of specification that apply in situations where workspace is mixed with either residential accommodation, or other types of workspace. The tables focus on those criteria which relate specifically to mixed situations, and all other characteristics of the individual typologies described earlier in this report remain relevant.

Page intentionally blank

1. Small office type space

	Block Level	Building Level
Access & Servicing	<ul style="list-style-type: none"> — Given the typically limited floor area of small offices, this typology is often provided as part of mixed use schemes. — Blocks of small offices do not require special entrance arrangements or intensive servicing. — Parking provision for employees should not conflict with other commercial users or residents in the neighbourhood. — Offices generally need accessible locations – so clients are able to access businesses, and businesses are able to access core market areas. 	<ul style="list-style-type: none"> — While servicing of small offices will not be significantly different from servicing residents, it is important to ensure that respective servicing requirements do not come into conflict. — In particular, that the servicing of offices does not impact residential amenity. — A clearly defined entry way and intercom which differentiates residents from non-residential occupants is best. — Parking arrangements must be managed so that any off-street parking provided does not create conflicts between the different uses. — Domestic and commercial waste storage and access must be segregated unless this is explicitly managed through a commercial contract.
Environmental Issues	<ul style="list-style-type: none"> — Environmental considerations are minimal. Refer to individual typology specification. 	<ul style="list-style-type: none"> — Environmental considerations are minimal. Refer to individual typology specification.

	Block Level	Building Level
Exterior & Interior	<ul style="list-style-type: none"> — There are no particular considerations except with regard to how a block of small offices interacts with other uses at street level. — Optimising the opportunity for active frontages and a diversity of uses in an immediate area creates a more secure and attractive environment. 	<ul style="list-style-type: none"> — The impact of small offices on the residential/non-residential space above should be minimized. Common space (if applicable) should be designed to ensure clearly delineated and secure functional boundaries between uses as well as good residential amenity. — Residents can either access their units from the street frontage with shop-front design or from a first floor podium as long as functional differentiation is sufficiently legible. — Multiple core with separate accesses improves security (secure by design), means of access and escape, fire compartmentation, identity, and level of fit-out. — A shared entrance allows for minimal external works but means the lobby has to lead to alternative spaces. There is potential for loss of identity of either use. Adds complexity to fire requirements and security. — The quality of the separation between the uses is key to the maintenance of each use's identity. This extends to fire risers, fire detection and monitoring, security, sound transfer, waste, external servicing and mechanical services.
Other Design Considerations	<ul style="list-style-type: none"> — Best located in established locations where demand is highest to maximize viability. 	<ul style="list-style-type: none"> — Vertical mixing of individual office units with residential uses can to be less attractive to some users who seek a 'business' address and/or those who are looking to be part of a workspace cluster. — Can consider sharing of lifts using access security which limits user access to particular floor. There is a need to assess vertical movement of furniture so may be requirement for a goods lift for residential, but this will depend on whether the offices are multi-storey beneath the residential element.

2. Large office type space

	Block level	Building level
Access & Servicing	<ul style="list-style-type: none"> — The considerations for how an office block interacts with adjacent uses are limited. The limited parking and loading that takes place should minimise conflict with residential uses. This means appropriate access routes and servicing to be done away from street fronts. — Optimising the opportunity for active frontages and a diversity of uses in an immediate area creates a more secure and attractive environment. 	<ul style="list-style-type: none"> — Large offices (more than small offices) are likely to require a higher degree of servicing which may require loading and some parking. There is a greater likelihood of conflicts with residential uses. — Measures to mitigate the impact of deliveries and loading will depend on configuration of site and the building entry points. In off street servicing areas clear paths for pedestrians should provide safety zone from delivery vehicles. If deliveries take place at the street frontage then inset bays could accommodate deliveries but must provide sufficient clearance for pedestrians. — Public realm can be used to ensure that the pavement surface is safely shared. — Multiple cores are ideal to separate the office and residential access. This improves security (Secure by Design), means of access and escape, fire compartmentation, and identity. — As with the small offices, there can be a co-joined entrance but the disadvantages will be amplified. — Domestic and commercial waste storage and access must be segregated unless this is explicitly managed through a commercial contract.
Environmental Issues	<ul style="list-style-type: none"> — Environmental considerations are minimal. 	<ul style="list-style-type: none"> — For walls, floors, airbourne sound insulation for offices needs to achieve typical standard. — Key design features to mitigate noise include glazing, doors, ventilation, building orientation, external walls and roof, separating walls, internal walls and floor performance, reverberation controls and room acoustics, external noise acoustics, protection from plant rooms/zones, communal areas. — Suitable sound attenuation treatment to externally sited chiller units for residential units.

	Block level	Building level
Exterior & Interior	<ul style="list-style-type: none"> — There are no particular considerations except with regard to how the typology interacts at street level. — Optimising the opportunity for active frontages and a diversity of uses in the immediate area creates a more secure and attractive environment. — Design should be consistent with rhythm of existing built structures. 	<ul style="list-style-type: none"> — The impact of this typology on residential space should be minimised and the non-residential space and all common space should be designed to ensure legible and secure functional boundaries between uses as well as good residential amenity. — The quality of the separation between the uses is key to the maintenance of each use's identity. This extends to fire risers, fire detection and monitoring, security, sound transfer, waste, external servicing and mechanical services. — It is more likely with large offices that separate street-level access is required established.
Other Design Considerations		

3. Studio type space

	Block level	Building level
Access & Servicing	<ul style="list-style-type: none"> — Parking and loading for studios is intermittent but conflicts with residential / other non-residential uses should be minimized by loading/delivery to be routed in a way that does not cause conflicts. — There is also potential for servicing of studios to be of an equal or greater scale than offices and residences so consideration should be given. — Appropriate access routes and servicing should take place away from street fronts. 	<ul style="list-style-type: none"> — Dedicated loading/unloading access to the building with enough space for rigid HGV circulation that is separated from residential parking / cycling storage / pedestrians / access. Pathways for residents should be clearly marked and ample to ensure safety taking into account required delivery vehicle movement. — If studio accommodation interacts with streetscape it must not conflict with access to building by residents or overall pedestrian safety. — Domestic and commercial waste storage and access must be segregated unless this is explicitly managed through a commercial contract.
Environmental Issues	<ul style="list-style-type: none"> — Incorporation of filtering /screening technology will be typically required to maintain acceptable air quality/minimise the impact of emissions on adjacent uses. — Boundary structures of a minimum height and specification can help to screen emission and sounds to limit impact on adjacent uses. 	<ul style="list-style-type: none"> — Air quality and noise are issues that will typically arise and need to be controlled. — Building design needs to be carefully considered to ensure no conflicts with regard to noise and air quality. Walls, floors, airbourne sound insulation for studios needs to achieve typical standard. — Residential accommodation above studio need separation by a fire rated structural division floor incorporating acoustic dampening in compliance. — Careful design also required to accommodate studio requirements for light. Windows should ideally reflect room height. Balanced light would be optimised with north-facing windows. This should be considered in respect to the window/light patterns for the residential/non-residential uses. — Central extract system (maybe a scrubber unit) linked to each studio minimises impact on residential amenity.

	Block level	Building level
Exterior & Interior	<ul style="list-style-type: none"> — There are no particular considerations except with regard to how the typology interacts at street level. — Optimising the opportunity for active frontages and a diversity of uses in the immediate area creates a more secure and attractive environment. — Design should be consistent with rhythm of existing built structures. 	<ul style="list-style-type: none"> — Legibility of space so that an observer can understand the relationship between the uses. Clearly defined routes to both studios and residential using materials to enhance experience and immediate building facade. Landscaping, Hard and soft landscaping as appropriate. Defined separation also key for security and safety. — External movement to be physically separated between studio and residential. Provision of internal loading / unloading space (temporary storage). — Inside, corridors wide enough to move materials but not so wide to become a storage area. Vertical movement via a goods lift for floor to floor movement
Other Design Considerations	<ul style="list-style-type: none"> — Can be located within mixed use neighbourhoods – if uses are compatible (i.e. do not have noise or pollutant impacts) then occupiers seek mixed use locations which can provide animation, however vertical mixing is unlikely to be attractive. 	

4. Small industrial/ warehouse type space

	Block Level	Building Level
Access & Servicing	<ul style="list-style-type: none"> — Locate parking and loading facilities behind buildings and when possible, provide access through an alley or secondary street. — When possible, orient primary industrial delivery/loading access to sides and rear of site, or along industrial alleys where residential entrance occurs along more commercial street; conversely, orient housing along small-scale residential alleys where children can play, and orient industry towards truck-heavy industrial streets. 	<ul style="list-style-type: none"> — Access for heavy goods and other service vehicles should be routed away and segregated from residential areas. — This can be accomplished by creating separate parking and access paths for ground floor industrial and upper floor residential. — Loading facilities possibly integrated to indoor areas where practicable. — If delivery and loading are accommodated at building frontage then dedicated loading bays or shared inset bays can be introduced. Shared solutions such as inset bays are better for mixed use environments. — Domestic and commercial waste storage and access must be segregated unless this is explicitly managed through a commercial contract.
Environmental Issues	<ul style="list-style-type: none"> — Incorporation of modern technology for filtering /screening of emissions is essential in order to maintain acceptable air quality/ minimise the impact of emissions. — Boundary structures of a minimum height and specification can also help to screen emission as well as the enclosure of the service space with buildings. — Screening activity should be applied on a case by case basis rather than by attempting to restrict entire industries or to zone out types of uses for the site. — Noise levels can be reduced through the use of planting, canopies, arcades and set-back facades. Necessary to satisfy normal planning requirements. 	<ul style="list-style-type: none"> — Incorporation of modern technology for filtering /screening of emissions is essential in order to maintain acceptable air quality/ minimise the impact of emissions. — Between residential and industrial uses, provide sound insulation and resilient channels at walls and ceilings. — Loading bays reduce impact on residential uses above. Optimal if loading facilities are integrated to indoor areas. — At residential units, provide super insulated windows, and Z-vents to replace windows as primary air intake. — Planning conditions can be introduced to manage the hours of operation for activities that have the potential to impact residents. Appropriately segregated waste disposal should be implemented.

	Block Level	Building Level
Exterior & Interior	<ul style="list-style-type: none"> — A cohesive street character can be maintained through a consistent pattern of access, orientation, and scale. — Physical elements (such as patterns of ground floor points of entry/access, ground floor apertures and heights, and building scale) contribute to a compatible neighborhood fabric despite disparate, adjacent uses. — Guidelines may be proposed that preserve and extend this pattern, taking into account loading and parking requirements. 	<ul style="list-style-type: none"> — In vertically integrated buildings, the typical construction method is a “concrete podium” over the ground floor industrial and parking uses, other uses above the podium. — Minimum ground floor height for podium should be 4.3-5.5m to allow industrial machinery, venting, etc. — 5.5m height allows two floors of parking at rear, under podium; 4.3-4.6 m height can allow usable mezzanine spaces for office or storage within the industrial space. — Providing an entrance to other uses from first floor podium allows for a shared entrances at ground level for the different uses. — Separated service yard / loading areas, where noise and vehicle traffic most generated.
Other Design Considerations	<ul style="list-style-type: none"> — An active and vibrant mixed-use neighborhood is not reliant on every building achieving an integration of uses but rather that there is compatibility between buildings with distinct uses. — Ancillary gallery and café spaces are a good way of giving studios and small industrial uses a public face and creating a viable use. 	<ul style="list-style-type: none"> — Important spatial relationships need to be established within the same building allow for integration of different uses and flexibility of use. — Guidelines might be proposed for certain sectional requirements and recommendations for street to building relationships.

5. Large industrial/ warehouse type space

	Block level	Building level
Access & Servicing	<ul style="list-style-type: none"> — Servicing can be achieved without the need for service courtyards taking up many metres of façade, and can instead be enclosed within the block. A clear access strategy is necessary to neither compromise use of retail, nor security for the dwellings. — For access to the industrial unit for staff parking and HGV it is best from a main road or dedicated road to separate it from residential / non-residential traffic / residents. — Required capacity for lorry turning is significant which means the site must be located with appropriate road access and a large goods yard for HGV manoeuvring. 	<ul style="list-style-type: none"> — HGVs, cycle and car parking for office/ customer use must be separated from residential access parking for amenity and safety. — Efficiency of land take by industrial unit should preclude surface car parking, but on-street, basement, courtyard and upper floor bike and car parking are all suitable options. — Built parking should have separate entrances other non-residential and residential uses. The building will have parking requirements both for residential tenants and for staff and customers of industrial uses; parking competes with industrial uses for ground floor space - consider lowering parking requirements for residential uses. — Domestic and commercial waste storage and access must be segregated unless this is explicitly managed through a commercial contract.
Environmental Issues	<ul style="list-style-type: none"> — Consider adverse affects that any restrictions on hours of operations might have on industrial uses. — Externally fixed floor mounted mechanical equipment shall be screened or housed within an acoustic shell or with acoustic louvered structure — In a majority of cases there will be no emissions causing air quality issues relating to general use. For special cases, there will be need for either an LEV (local extract ventilation) system or a mechanical scrubber unit for removing pollutants or irritants from the air. 	<ul style="list-style-type: none"> — Industrial workers often arrive on-site before commuting office workers leave the residential element - implications for both noise considerations and shared access routes. — Incorporation of modern technology for filtering /screening of emissions is essential in order to maintain acceptable air quality/ minimise the impact of emissions. — Provide vent chases for necessary ducts through residential floors. Provide proper plumbing and sewer hookups, utility sinks, traps, vent hoods, etc., for industrial cleanup needs. — Provide sufficient trash and disposal areas for industrial needs, including disposal of solvents and hazardous wastes.

	Block level	Building level
Exterior & Interior	<ul style="list-style-type: none"> — A cohesive street character can be maintained through a consistent and well-conceived pattern of access, orientation, and scale. — Physical elements (such as patterns of ground floor points of entry/access, ground floor apertures and heights, and building scale) contribute to a compatible neighbourhood fabric despite disparate, adjacent uses. — Guidelines may be proposed that preserve and extend this pattern, taking into account of loading and parking requirements. 	<ul style="list-style-type: none"> — Residential will need to be accessed from separate street frontage, such as shop-front design. — The impact on residential development of the non-residential space below should be minimized. Common space should be designed to ensure clearly defined structures / ownership boundaries and adequate residential amenity. — The need for segregation of industrial uses from residential is greatest in this case.
Other Design Considerations	<ul style="list-style-type: none"> — Wrapping larger scale industrial activities with associated softer office space can create a positive frontage to the street. — Wholesale/storage spaces prefer not to have immediately adjacent buildings due to security reasons and increased insurance risks. 	

6. Yard type space

	Block level	Building level
Access & Servicing	<ul style="list-style-type: none"> — Production Yard – well segregated from surrounding uses. Will need access/egress width through an entrance to provide 2 way flow where it abuts a main road. Allowance of 8.0 clear would be acceptable, recessed to enable the traction unit to gain clear vision of traffic. — Services Yard – Public facing access required — For deliveries, the site needs to accommodate light / medium vehicles and to also accommodate side loading scenarios. — For staff / visitor parking of small vehicles, it must be well delineated to avoid conflicts with residential road use, down a dedicated access road, from suitable sized link road — Provision of adequate fire appliance access is also required. 	<ul style="list-style-type: none"> — Access for heavy goods and other service vehicles should be routed away and segregated from residential areas. — This can be accomplished by creating separate parking and access paths for ground floor industrial and upper floor residential. — Domestic and commercial waste storage and access must be segregated unless this is explicitly managed through a commercial contract.
Environmental Issues	<ul style="list-style-type: none"> — Noise at boundary will need to satisfy normal planning requirements. But boundary structures will need to provide sound attenuation specification. 	<ul style="list-style-type: none"> — Restricted Hours of Operation will be necessary, as well as light pollution. Directional lighting is also advisable.

	Block level	Building level
Exterior & Interior	<ul style="list-style-type: none"> — Security and safety is paramount. Lighting, building form (if relevant), hidden areas are all concerns to ensure security and amenity to residential / non-residential uses. It is important to seek local guidance from Police Architectural Liaison Officer in this instance to ensure safety and security of adjacent uses. — High security boundary fencing, including communal gating, where practicable. — The space must be secure, well- lit with CCTV and alarm system. Clearly associated parking facilities with access from different angles if possible to prevent creating an enclosed space. — Materials appropriate to the setting. — Maximum controlled heights in order to appropriately secure surrounding uses. — Appropriate manageable hardstandings. — Building and fire regulations must be considered carefully. While the escape distance may not be an issue, the division / spacing of the units (if relevant) will require adequate fire resistance provision 	<ul style="list-style-type: none"> — Security and safety is paramount. Lighting, building form (if relevant), hidden areas are all concerns to ensure security and amenity to residential / non residential uses. It is particularly important to seek local guidance from Police Architectural Liaison Officer in this instance.
Other Design Considerations		

3C

MIXED USE

ILLUSTRATIONS

Delivery Vehicle Access

Requirements for size of vehicle access should be determined depending upon employment space typology in the mixed use development. Access for articulated vehicles may be controlled at a neighbourhood level by a comprehensive masterplan, particularly in new town centre areas.

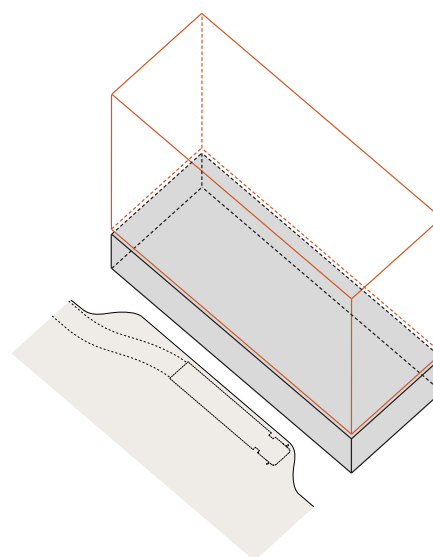

For HGV access, it must be possible for vehicles to enter and leave a site in forward gear (no reverse gear onto public highways). The diagrams opposite demonstrate a range of potential options in order to achieve this.

Key reference documents for matters relating to vehicle access and deliveries include: 'Designing for Deliveries: a Planners' Guide to Truck Turning & Deliveries', FTA, and 'Kerbside Loading Guidance, 2009', TFL.



↑ Lay-by access

KEY

-  Residential
 -  Employment space
 -  Vehicle loading
-

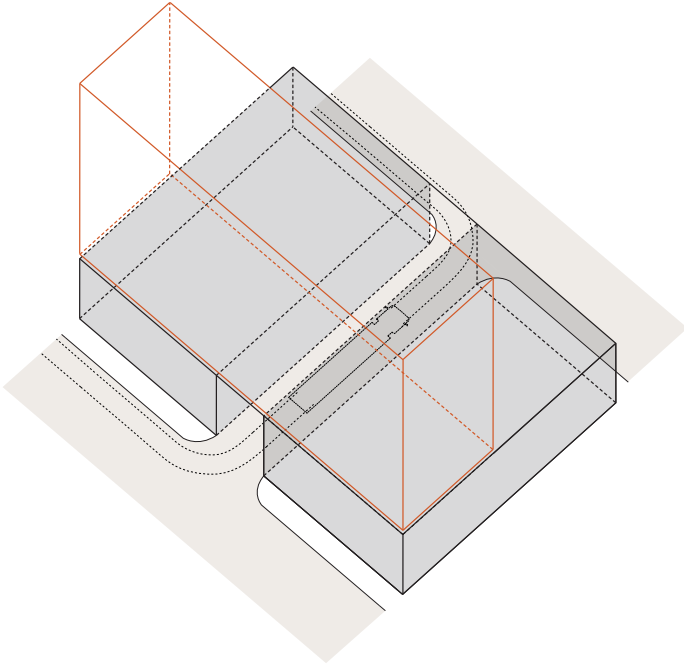

↑ Internal loading bay with through-access

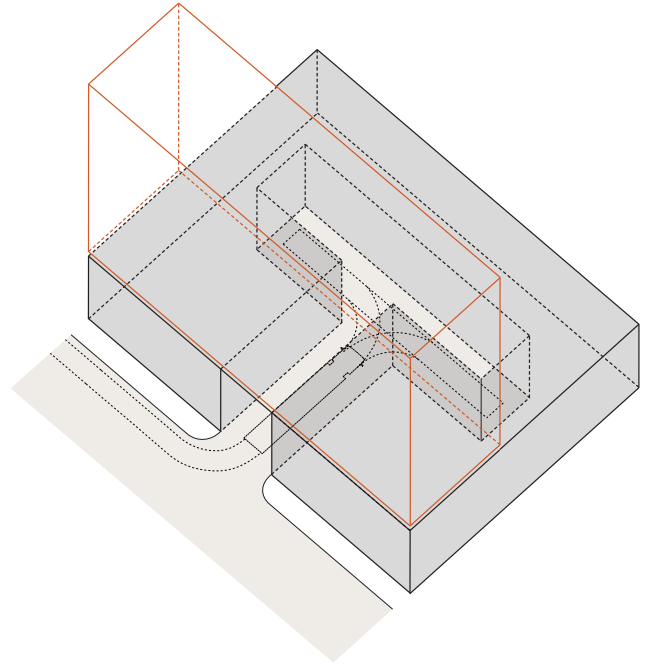

↑ Internal loading bay with turning space

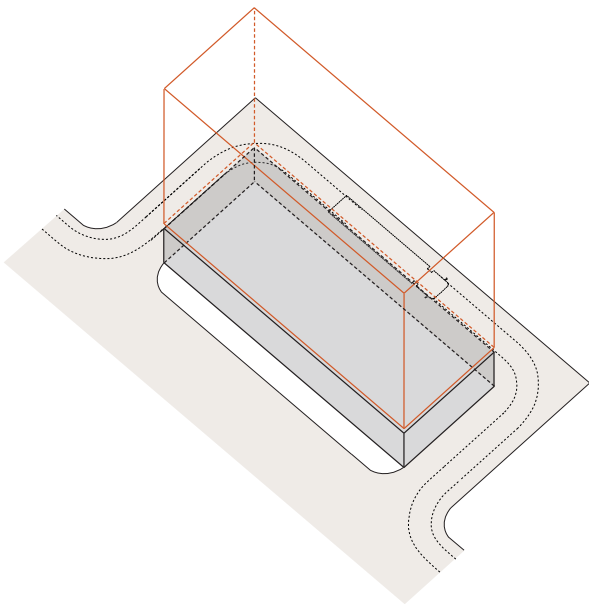

↑ Rear loading yard

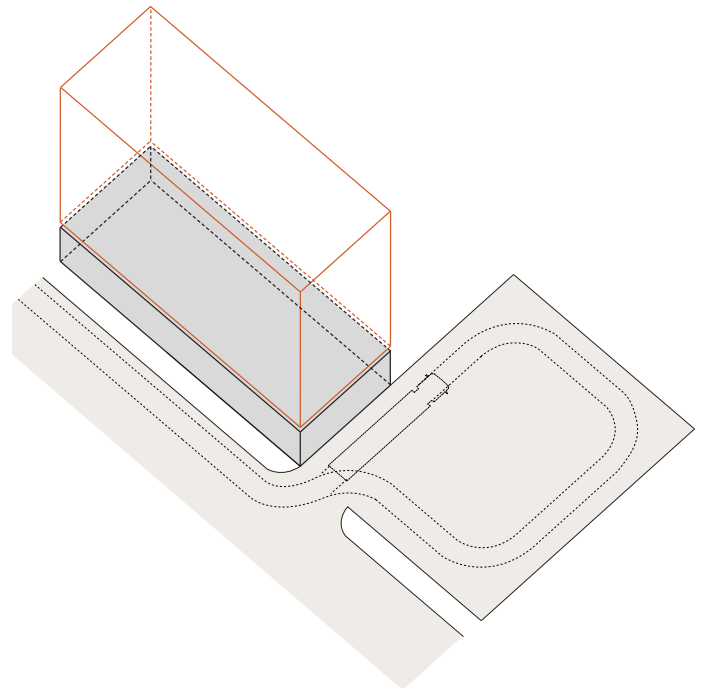

↑ Side loading yard with turning space

Entrance Arrangements

Generally, separate entrance are required for residential, workspace and loading access. The diagrams opposite demonstrate a range of separated servicing arrangements

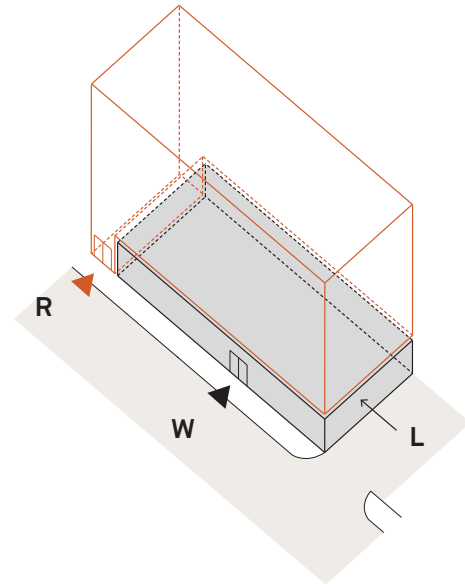

↑ Pedestrian access from street, loading to side

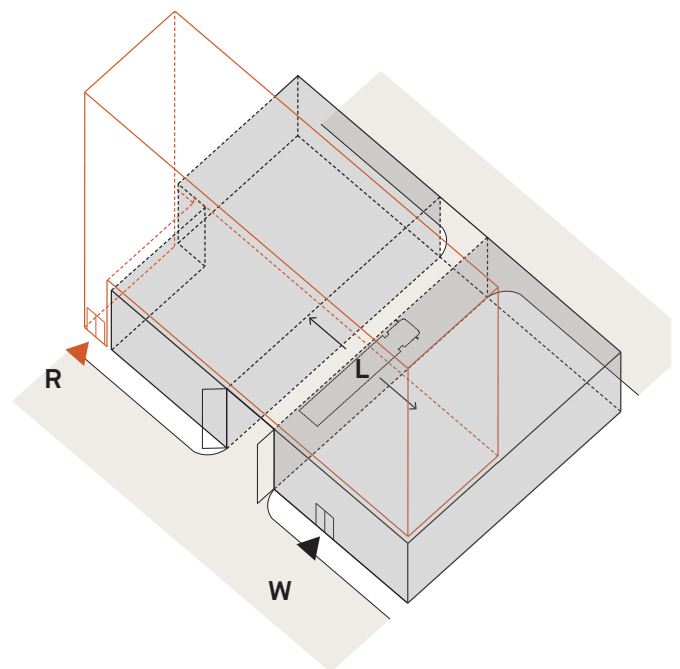

↑ Pedestrian access from street, internal loading

KEY

- Residential
 - Employment space
 - Vehicle loading
 - R** Residential access
 - W** Workspace access
 - L** Loading
-

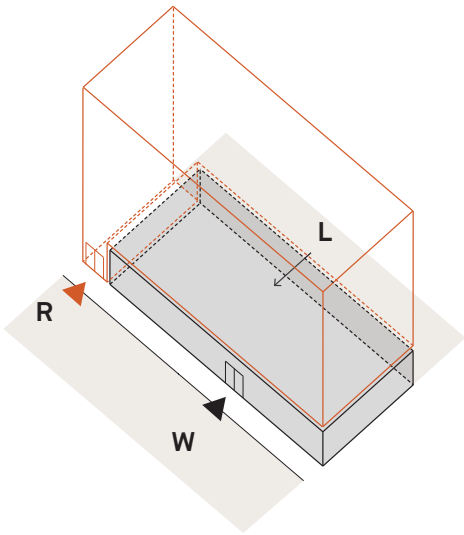

↑ Pedestrian access from street, loading from rear

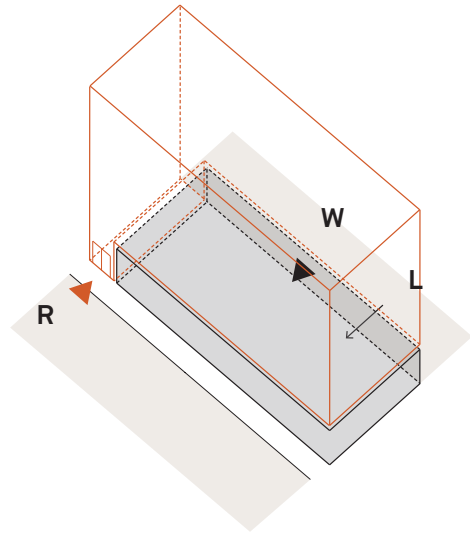

↑ Residential access from street, workspace access and loading from rear

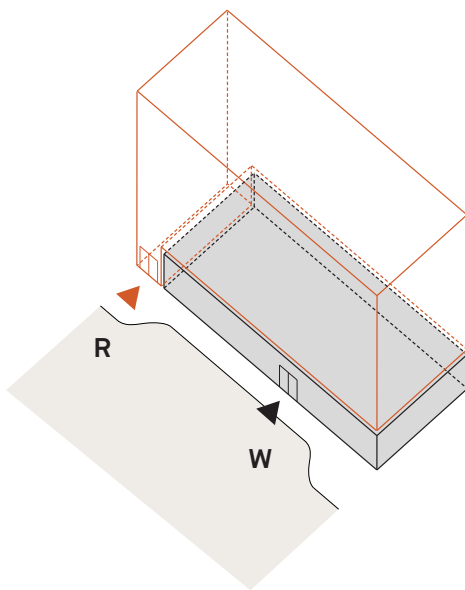

↑ All access from street side

General Design Principles

In addition to the typology specific design considerations included in this report, the following general principles can help to successfully integrate mixed use development into neighbourhoods.

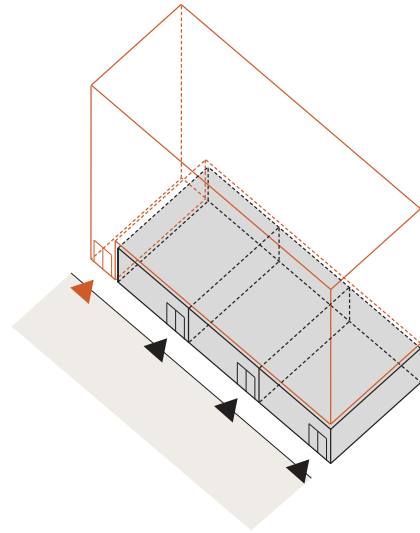

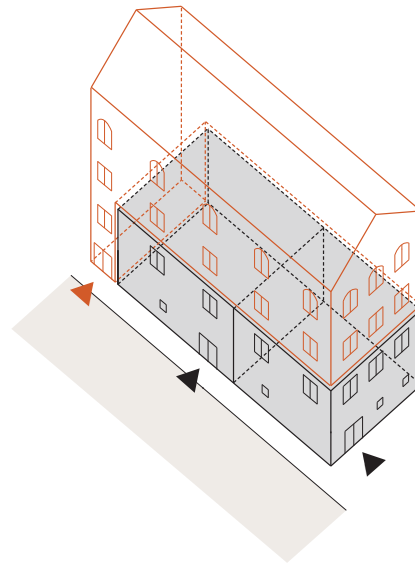

↑ Maximise number of street frontages to avoid blank facades. Provide appropriate signage for street-facing units.



↑ Adaptive reuse of existing buildings can achieve characterful work and residential spaces.

KEY

-  Residential
 -  Employment space
 -  Vehicle loading
-

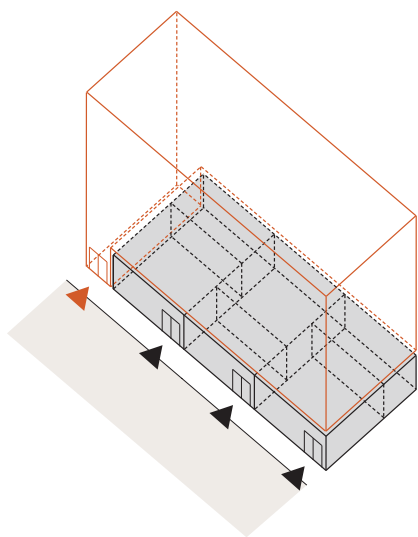

↑ Flexible internal layouts allow for varied occupiers and future adaptation.

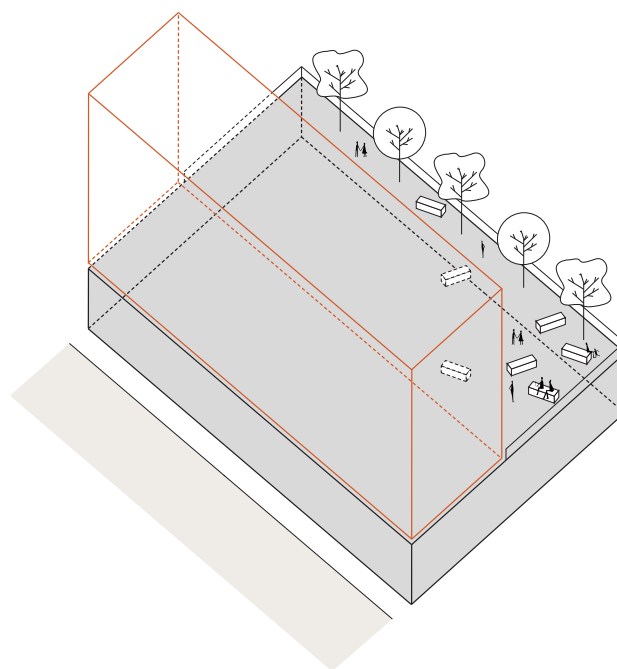

↑ Deeper floorplates for workspace uses at ground floor can offer amenity space to residential uses above.

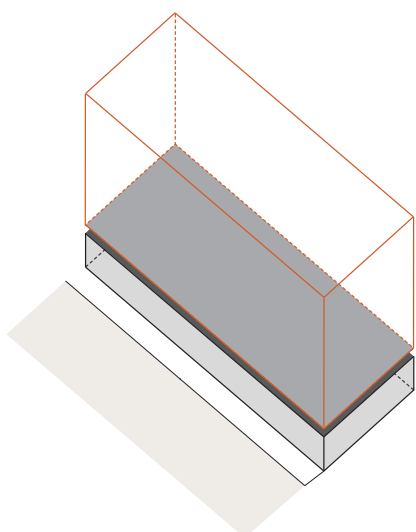

↑ Separation of different uses should be achieved through appropriate structural and acoustic specification of construction.

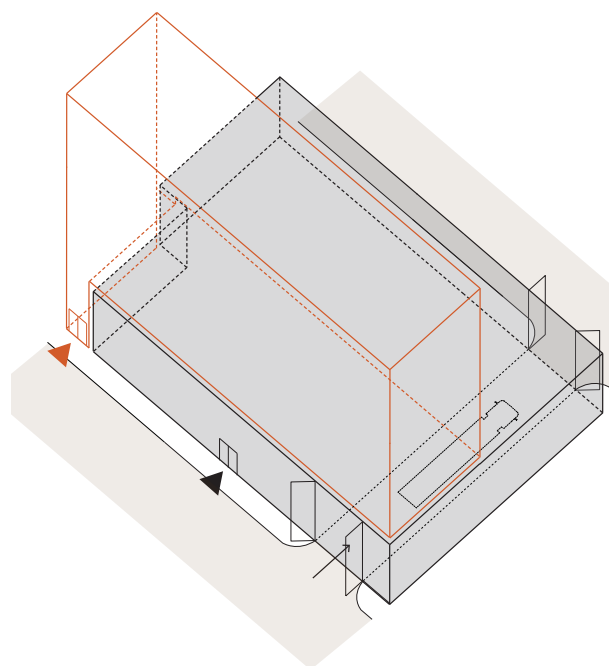

↑ Allowing sufficient floor-to-ceiling heights for internal vehicle servicing can further reduce impacts on neighbouring uses.

3D MIXED USE CASE STUDIES

Chips Building



↑ The building hosts ground floor commercial uses including the Fab Lab, and residential uses above.

Project

- Chips Building, Lampwick Lane, Manchester
- Alsop Architects for Urban Splash Ltd.
- Total area: 16,200m² (174,375sq.ft)
- Status: completed 2010

Mix

Building scale mix
Maker space + residential

About

A new-build residential development of over 140 apartments in Manchester, incorporating office, workspace and leisure uses on the ground floor. Chips is made up of three equal-height, long build masses. Each is approximately 100m x 14m wide, staggered on top of one another. The combination creates an elevated ground floor and eight storeys totalling 142 1-3 bedroom apartments. The development demonstrates a successful mixing of workshop/maker uses with residential units in a desirable new-build.

Employment Space & Management

The ground floor, which accommodates work and amenity spaces, encompasses a central triple-height lobby, 507m² (5,457sq.ft) made up of five units for office and workshop use. These commercial spaces are flexible in size and arrangement and an array of uses are possible. In addition the ground floor hosts one large 420m² (4,521sq.ft) unit intended for a restaurant operation which is used as a day nursery. Other ground floor units house a health and wellbeing centre and an art gallery.

One of the ground floor units is occupied by the Manchester Fab Lab. The Fab Lab provides a workspace for product designers and entrepreneurs to build and test designs as cheaply and easily as possible. The Fab Lab offers latest digital fabrication equipment including 3D printers, laser cutters, moulding and milling equipment as well as electrical components, circuit boards and soldering equipment. Nearly 2,000 registered users make regular use of the space and equipment. Users pay only for the materials they use, and are asked to share their projects onto the Fab Lab online projects database.

Access & Servicing

In terms of access, the design provides one front door for all residents, with all apartments access through a glazed lobby to the centre of the building. Studio spaces, workspace and amenity space on the ground floor have their own entrances. The basement level of the development accommodates parking provision for residents, with 10% allocated to disabled parking provision. The basement also houses bicycle parking and waste/refuse store areas. The Chips site is 28m at its widest point and 120m long, accommodating a level change of approximately 2.5m.

Environmental Issues

The digital manufacturing offered by Fab Lab is serviced by localised extracts, and has minimal noise or emissions.

Exterior & Interior

Previously the site of a disused hospital ward block, the site is bounded on the north west and south east by canals, and additional canal arms have been constructed to the east and west of the site to enclose it with water on three sides.

Internally, each apartment is designed around a central 'pod' unit and folding screens allow for maximum flexibility in creating open plan or sub-divided spaces. Externally, the building is clad in a composite wall, covered in newspaper print text in reference to the area's industrial heritage.

Viability & Project Costs

Total project costs of around £20m put the project cost/m² at around £1,235. Currently average sale price estimates for residential units range from £120,000 for a 1-bed to £201,000 for a 2-bed, with a current average value of £158,905. A ground floor commercial unit of 110m² (1,184sq.ft) is currently on the market for £149,995.

Key Feature/Success

- Fab Lab use demonstrates that such digital manufacturing workshops do not necessarily require typical 'industrial' space, and can take place in conventionally 'office-like' environments in new developments.
- Provision of flexible commercial space at ground floor level which have been occupied by a range of uses.
- Stacking of residential uses which contributes to successfully buffering from commercial operations on the ground floor.
- Successful arrangement of access requirements, with primary residential access facilitated through a central lobby, and ground floor studio access provided separately.
- Provision of amenities and workspace on the ground floor which serve both in-house residents as well as attracting others from the neighbourhood and even city-wide scale.

John Jones Arts Building



↑ Although built specifically to provide production, office and gallery space for John Jones, the top floors of the Arts Building provide flexible, separate office space that can be leased to other users.

Project

- The Arts Building, Finsbury Park, London
- David Gallagher Associates with Spiritbond
- Total area: 5,296m² (57,006sq.ft)
- Status: completed 2014

Mix

Building scale mix
Light industrial space + office space + residential

About

Located behind the Finsbury Park station, the Arts Building scheme is a 6-storey development comprised of dedicated facilities for bespoke framing company John Jones- specialists in fine art and conservation- alongside a student accommodation courtyard scheme and 15 affordable housing units and commercial units. Described as a 'New York style warehouse', the 6-storey building includes design studios, conservation room, fitting and artwork presentation workshops. The scheme forms part of the wider

regeneration of the area, contributing to the growing identity of the area as a cultural hub. The site was previously a low-rise industrial estate.

Employment Space & Management

The development provides employment space in a dedicated workspace building, adjacent to the residential buildings in the scheme. Employment space is primarily provided through John Jones as the anchor employer, occupying most of the lower three floors, with other smaller workspace units available for rent. Other office and commercial units to let within the workspace building include the entire 5th floor and smaller units on the floors below. Total on-site employment is estimated at around 120 people. The building also hosts an on-site cafe which serves both on-site employees as well as the public. Office units are accessed via a communal stair core or passenger lifts.

Access & Servicing

Activities housed in the building include framing, collection care, research, artwork conservation and public and educational events. Frames are made in Hertfordshire and delivered daily to Finsbury Park for fitting. The housing and workshop surround a central courtyard and enclosed vehicle yard which facilitates these daily delivery needs. Specialist humidity and climate controlled storage facilities are also in place to manage and store artwork correctly.

Exterior & Interior

The main workspace hosts frame making uses, storage, machine workshops, office space, gallery space and 267m² of retail space. Wrapped around a 1,000m² internal service yard, an adjacent building hosts 475-room student accommodation.

Workspaces are available for rent across the 3rd, 4th and 5th floors of the Arts Building. The fifth floor hosts a large 485m² (5,200 sq.ft) unit, a shared reception room and 24/7 access. Office

units on 3rd and 4th floors range between 35-85m² (350- 900 sq.ft). Ceiling heights range from 2.8-3.4m. Amenities include shell and core finish to the 5th floor, private roof terrace on 5th floor, polished concrete flooring, on-site cafe, communal kitchenette on 4th floor, passenger and goods lifts, loading bay and shower facilities and cycle parking on-site

With experience hosting ad hoc exhibitions in their previous premises, John Jones looked to facilitate and formalise this cultural offering in their new premises, facilitated through a 93m² (1,000sq.ft) gallery space.

Viability & Project Costs

The £10m project received supported from Islington Council and Arts Council England. Current office space available to let in the building are offered on 5-10 year leases at around £40/sq.ft across all floors.

Key Feature/Success

- Construction was phased in order to limit disruption to John Jones's business operations.
- A variety of creative businesses in residence in the building animates the building across differed spaces and different hours of operation.
- Internal vehicle yard allows for maneuvering to ensure forward-in, forward-out driving.
- Provision of local amenity (cafe and gallery) on the ground floor, animates the building at street level.
- Providing residential units in an adjacent building rather than mixed within one building enabled more flexibility in the workspace offering of the Arts Building.

APPENDIX: NOISE MITIGATION MEASURES

This section provides details of key measures for the mitigation of noise that are relevant to development in a mixed use environment. This can serve as the basis for discussions with planning applicants to ensure that residential amenity is maintained in areas with high levels of commercial activity. Some local authorities provide their own noise mitigation guidance to ensure that their standards are higher than those in the Building Regulations.

Glazing

The full sound insulation value of any window cannot be realised if there are air gaps. These commonly occur around frames due to insecure fixing, poor maintenance, and gaps between frames and opening lights.

Timber frames generally degrade over time and suffer acoustic degradation caused by wood shrinkage opening up joints and seals.

Window manufacture for offices and apartments benefits from a 2 part metal frame construction with a thermal break. Constructed to finer tolerances with machine manufactured parts, fitments and seals provide a sealed window frame component.

Gaps between frame and structure should be suitably sealed with a non-hardening mastic to prevent future shrinkage due to UV issues.

The glazing options vary. Typically, thicker glass offers better sound insulation than thinner glass, particularly when the major problem is low frequency noise such as truck engine or music noise.

Laminated glass performs slightly better than other types of glass when the major problem is high frequency noise. The improvement is due to a PVB (polyvinyl butyral) interlayer that helps to reduce the passage of sound at high frequencies. This layer is sandwiched between two panes of glass. However, laminated glass offers little improvement over other glass of the same thickness when the main problem is low frequency noise.

Small air gaps between panes of glass can provide good thermal insulation properties but only offer minimal acoustic insulation. To achieve good thermal insulation double glazed systems should have an air gap of about 12mm between each pane of glass, whereas to achieve good acoustic insulation the air gap should be between 50mm and 150mm. It is important to distinguish between thermal and acoustic insulation as some glazing suppliers may not specialise in both areas.

To maximise the glazing benefits, a double glazed unit should be manufactured using two different thicknesses of glass, for the average size of window (say 1.0m x 1.0m) an 8mm pane and a 6mm pane are more effective against varying sound waves. There needs to be a balance struck between thermal and acoustic insulation. The optimum air gap for a vacuum sealed double glazed unit for thermal is 20mm and this should provide notional sound reduction as well.

Triple glazing is an option and this would enable thinner glass to be employed, such as 4mm pane x 3 with 16mm air gap x 2. We would expect a sound reduction similar to the double glazed unit of 38 dB Rw, though the thermal improvements would be enhanced.

In particular noisy locations the installation of a secondary window system is preferable with a minimum of 100mm air space but preferably 300mm and the sides and top lined with sound-absorbing material.

Doors

The main factors determining the sound insulation of a single door set are the mass of the door and the gaps around the edges; usually, the latter are critical. For good sound insulation, the door should form airtight joints with the frame when closed and the joints between frame and wall should be sealed. A threshold seal is essential, and even keyhole covers should be fitted in critical situations.

All doors should be supplied as door-sets (door leaf and frame supplied as a manufactured unit) and

of solid core construction, with integrated seals between frame and door leaf.

Single door sets providing a sound insulation greater than 35 dB Rw are specialist products and are normally supplied as complete door sets. High performance seals might make the door hard to open and close.

Ventilation

For apartments where ventilation is natural (not forced) The Building Regulations’ supporting documents on ventilation recommend that habitable rooms in apartments have background ventilation. Where openable windows cannot be relied upon for this ventilation, trickle ventilators can be used and sound attenuating types are available. However, windows may remain openable for rapid or purge ventilation, or at the occupant’s choice.

Alternatively, acoustic ventilation units are available for insertion in external walls. These can provide sound reduction comparable with double glazed windows. For office, and or apartments where ducted heating and ventilation systems are utilised there are noise ratings set out within the CIBSE Guide A for building services (see table opposite).

Building orientation

For guidance the developer of a mixed use development should carry out an assessment in accordance with BS4142 to determine the rating level of the new development. It is recommended that during normal daytime hours (0700 to 2300 hours), the BS4142 rating level, measured over 1 hour, should be 5dB below the background. During the night-time period (2300 to 0700 hours), the BS4142 rating level, measured over 5 minutes should be 5dB below the background.

This will provide the local acoustic dynamics by which the developer can assess the measures required to minimise the impact of noise on the building and its occupants. Mitigation of noise

Space type	Noise rating
Apartment bedrooms	NR20
Apartment living space	NR30
Senior management offices	NR30
Offices, meeting rooms, small conference/lecture	NR35
Toilets and washrooms, office receptions, corridors	NR40
Apartment lobbies, corridors	NR40
Computer rooms, cafeteria	NR45

Source: CIBSE Guide A for building services

generated locally can be to orientate, where possible, the building so that the main access points and window facing elevations are not in direct line of main directional noise source. Alternative, acoustic treatment of the façade, improvement to window / access specifications may be introduced.

However, the acoustic issues are not the only aspects for defining the orientation of a building, be it office or industrial with mixed residential, the plot shape, access requirements, circulation, solar gain, external mechanical plant, transport requirements will all have to be balanced into the equation.

Walls and Floors - Sound Insulation between Spaces

If offices are directly adjoining residential properties the sound insulation requirements must meet the Building Regulation part E1 requirements as a minimum. This can also be controlled through the planning process and some local authorities may require the sound insulation to be better than the Building Regulations requirements.

In the absence of any local authority guidance the minimum airborne sound insulation required from the office spaces into the residential areas is 45dB $D_{nT\omega} + C_{tr}$ for walls and floors. If offices are located above residential properties the impact sound insulation should be 62dB $L_{nT\omega}$ or less.

Within the offices, the level of privacy will determine the acoustic requirements of partitions and door sets. For speculative developments partitions between small offices /meeting type rooms should be Rw 50dB, into circulation areas Rw40dB, and door sets to small occupied rooms should be Rw 30dB.

The tables overleaf set example construction types for walls and floors achieving the required Laboratory tested airborne sound insulation (Rw dB). It is important to note that construction details and workmanship are important if the levels of sound insulation indicated are to be achieved. Constructions might not achieve these laboratory performances in the field, even if correctly specified and correctly built, due to flanking transmission paths.

Acoustic Enhancement of External Facades

There are a number of ways of addressing the acoustic enhancement of the external façade, but the most important aspect is density. It should be said, the greater the material density, and of varying density build-ups to combat alternate sound waves, the better the sound reduction.

Composite Cladding façades, the material of choice for a majority of industrial and office construction, due to speed of erection and thermal enhancement,

is more likely to provide a performance in the region of 35dB Rw based upon the lightweight insulations. This can be improved with the installation of a rockwool filled composite cladding system to make it compliant.

Compliant construction details would be:

- A brickwork (100mm)/blockwork (100mm) cavity wall construction with an insulated 100mm wide cavity, lined on the inside face with 12mm of plasterboard and skim. (Seen in a number of domestic and apartment construction.
- Steel framed building with an external pre-cast concrete façade, and lined internally with an insulated stud wall construction faced in a minimum of 12mm plasterboard and skim. (offices and apartments)
- A steel framed building with external composite cladding façade (120mm), lined inside with a 210mm dense blockwork liner wall (industrial for robust operations)
- Steel framed building with composite cladding façade (120mm) and lined internally with an insulated stud wall construction faced with 25mm of plasterboard and skim. (offices and residential)
- A steel framed building with a rainscreen system on a blockwork outer leaf (210mm), lined internally with an insulated stud wall construction faced with 25mm of plasterboard and skim. (offices and residential)
- Steel framed building with a curtain walling façade, lined internally with an insulated stud wall construction faced with 25mm of plasterboard and skim below dado and above ceiling level.

Other noise sources, such as external mechanical plant areas are acoustically dealt with locally. This is normally in the form of an acoustic screen (louvred or perforated bespoke screens) to minimise the emanating noise. The level of noise reduction will be based upon the most sensitive receptor within the zone, be it the site boundary, the building or a local circulation route.

Common Areas

A typically accepted noise level in common areas is NR40. The specification of sound absorbing materials within these areas plays a vital role in reducing the noise levels and the resultant impact on neighbouring private spaces.

It is important to consider when selecting materials to aid absorption of sound, that these areas will also need to conform to the requirements of the Building Regulations Part B- Fire safety and that they will be also subject to a greater level of wear and tear.

Two ways of satisfying the building regulation requirements are as detailed below:

1. Cover and area with an absorber of an appropriate class according to BS EN ISO 11654:1997 Acoustic sound absorbers for use in buildings.
2. Determine the minimum amount of area using calculations in octave bands.

As this information is a guide, examples of typical requirements based on method 1 only are detailed:

- For entrance halls, corridors or hallways, cover an area equal to or greater than the floor area with a class C absorber or better. Generally most sensible to cover the ceiling as this is subject to the least wear and tear or physical damage in daily use.
- For stairwalls or stair enclosures: calculate the area of the treads and upper surface of landings (excluding the ground floor) and the ceiling on the top floor, and either cover an area at least equal to this with Class D absorbing material, or an area of at least 50% of this area in a Class C absorber. It is important to spread the absorbing material over all the floor levels. Often covering the underside of landings is a good area to select as again it is an area subject to less wear and tear.
- Typical materials which may be considered include British Gypsum Artec ceiling tiles, planks and boards that have a Class C rating. Suspended Ceiling tiles and wall panels by Ecophon have products with absorption class A.

Reverberation Controls

As with most modern construction, offices have a tendency to maximise the usable space either by open plan operations or cellular offices with hard walls, glazing, doors and in some cases hard ceilings. To reduce the reverberation of sound bouncing around the space, the use of noise reduction materials or products is a necessity. As a guide the quantity of absorption should follow the recommendations within 'A guide to office acoustics', which is a minimum of 0.21 per m³ of office space.

Absorbing excessive noise:

The application of acoustic ceiling tiles and reverb wall panels absorbs the sound energy reducing unwanted, reflected sound from surfaces such as glass and concrete and enhances speech clarity. Sound absorbing suspended ceiling tiles supplied by manufacturers such as Ecophon with their Focus E or Acoustic ceiling tiles. Similarly they produce a sound absorbing wall panels in suitably decorative finishes to enhance the installation. Hard ceilings (MF plasterboard ceilings) can, if the height is suitable, have sound absorbing hung baffles. These absorb and block reverberating noise and will be positioned to maximise the benefit.

Blocking emerging sounds:

The use of barrier products like dividing partitions, screens and cabinets block sounds from traveling across an office workplace. For some areas a Reverb Screen which has an extra dense core and absorbent outer surface will soak up the sound even more.

Cover unwanted sounds:

Using the latest computer based technology you can cover or mask unwanted office noise with the addition of extra random sound. As unlikely as this might seem, a fully digital sound masking system is highly effective.

Example wall	Design specification options
26 to 33 Rw dB	<ol style="list-style-type: none"> 1. 1 mm steel sheet panels fixed to steel frame members to form demountable partition units 50 mm overall thickness. Mineral wool cavity insulation. 2. Plywood or wood fibre board 12 mm thick nailed both sides of (50 × 50) mm timber framing members spaced at 400 mm centres. 3. Paper faced strawboard or wood wool 50 mm thick panels plastered both sides. 4. Chipboard hollow panels 50 mm thick tongued and grooved edges, hardboard faced. Joints covered with wood trim.
33 to 37 Rw dB	<ol style="list-style-type: none"> 1. Lightweight masonry blockwork. Plaster or drylining on at least one side. Overall mass per unit area not less than 50 kg/m². 2. Timber stud partitions any size timbers greater than (50 × 350) mm, 400 mm centres, cross noggins, 9.5 mm plasterboard lining on both sides, any suitable finish. 3. Metal stud partition, 50 mm studs 600 mm centres, clad both sides with 12.5 mm plasterboard, joints filled and perimeters sealed. Approximate mass per unit area 18 kg/m². 4. 50 mm lightweight masonry blockwork, plastered both sides to 12 mm thickness or drylined with 9.5 mm plasterboard.
37 to 43 Rw dB	<ol style="list-style-type: none"> 1. Lightweight masonry blockwork, plaster or dry lining on at least one side. Overall mass per unit area not less than 75 kg/m². 2. Either 75 mm or (100 × 50) mm timber studs (no noggins) spaced 600 mm apart, 50 mm mineral fibre quilt in stud cavity. Frame-lined on both sides with one layer 12.5 mm plasterboard. Approximate mass per unit area 19 kg/m². 3. Metal stud partition, 50 mm studs 600 mm centres, clad both sides with 15 mm plasterboard, joints filled and perimeters sealed. Approximate mass per unit area 26 kg/m².
43 to 50 Rw dB	<ol style="list-style-type: none"> 1. Masonry wall, joints well filled. Either plaster or dry lining on both sides. Overall mass per unit area not less than 150 kg/m². 2. 100 mm metal stud partition, “C” section studs not greater than 600 mm spacing, not less than nominal 50 mm web depth. Clad on both sides with two layers of plasterboard of not less than 22 mm combined thickness. Mineral fibre quilt hung between studs. Approximate mass per unit area 35 kg/m². 3. (75 × 50) mm timber framing using staggered studs at 300 mm spacing with 25 mm stagger forward and back. Frame clad with two layers of 12.5 mm of plasterboard on both sides. Mineral fibre quilt hung between studs. Approximate mass per unit area 36 kg/m². 4. (50 × 25) mm timber stud partition to form a 25 mm cavity, clad on both sides with minimum 38 mm wood wool slabs having their outer faces screeded or plastered. 5. Solid autoclaved aerated concrete blocks, 215 mm thick plaster or dry-lined finish on both sides, blockwork joints well filled. Overall mass per unit area not less than 160 kg/m².
50 to 54 Rw dB	<ol style="list-style-type: none"> 1. Two separate frames of timber studs not less than (89 × 38) mm, or boxed metal studwork with 50 mm minimum web depth. Studs at 600 mm maximum centres. A 25 mm mineral wool quilt suspended between frames. Frames spaced to give a minimum 200 mm overall cavity. Clad on outside of each frame with a minimum of 30 mm plasterboard layers (e.g. 19 mm plus 12.5 thickness). Approximate mass per unit area 54 kg/m². 2. Either in situ or precast concrete wall panel not less than 175 mm thick and not less than 415 kg/m². All joints well filled.

Example wall	Design specification options
50 to 54 Rw dB (cont.)	<ol style="list-style-type: none"> 3. Brick laid frogs up, wall nominal 200 mm thickness, weight (including plaster) not less than 380 kg/m². Plaster or dry-lined finish both sides. Brickwork joints well filled. "No fines" concrete 225 mm thickness, weight (including plaster) not less than 415 kg/m². Plaster or dry-lined finish both sides. 4. Cavity lightweight aggregate block (maximum density of block 1 600 kg/m³) with 75 mm cavity and wall ties of the butterfly wire type. Dry-lined finish on both sides. Joints in blockwork well filled. Overall mass per unit area not less than 300 kg/m². 5. Dense aggregate concrete block cavity wall with 50 mm cavity and wall ties of the butterfly wire type. Dry-lined finish on both sides. Joints in blockwork well filled. Overall mass per unit area not less than 415 kg/m². 6. Autoclaved aerated concrete block cavity wall consisting of two leaves, 100 mm blocks not less than 75 mm apart, with wall ties of the butterfly type. Plaster or dry-line finish on both sides. Joints in blockwork well filled. Overall mass per unit area not less than 150 kg/m². 7. Metal stud partition, 70 mm acoustic studs 600 mm centres, clad both sides with 15 mm plasterboard, joints filled and perimeters sealed. Mineral fibre within cavity. Approximate mass per unit area 26 kg/m².
54 to 60 Rw dB	<ol style="list-style-type: none"> 1. Two separate frames of timber studs not less than (100 × 50) mm, spaced at 600 mm maximum centres. A 50 mm mineral wool quilt in each frame between studs. Frames spaced to give a minimum 300 mm overall cavity. Each frame clad on outside with three layers of 12.5 mm plasterboard nailed to framing. Approximate mass per unit area: 51 kg/m². 2. Metal stud partition, 146 mm acoustic studs 600 mm centres, clad both sides with a double layer 15 mm plasterboard, joints filled and perimeters sealed. Approximate mass per unit area: 51 kg/m². 3. Solid masonry with an overall mass per unit area of not less than 700 kg/m², fully sealed both sides. 4. Dense aggregate concrete block solid wall 215 mm thick plaster finish to both surfaces. Overall mass per unit area not less than 415 kg/m². 5. Cavity lightweight aggregate block (maximum density of block 1 600 kg/m³) with 75 mm cavity and wall ties of the butterfly wire type. Plaster finish on both sides. Joints in blockwork well filled. Overall mass per unit area not less than 300 kg/m². 6. Dense aggregate concrete block cavity wall with 50 mm cavity and wall ties of the butterfly wire type. Plaster finish on both sides. Joints in blockwork well filled. Overall mass per unit area not less than 415 kg/m². 7. Metal stud partition, 146 mm acoustic studs 600 mm centres, clad both sides with a double layer 15 mm plasterboard, joints filled and perimeters sealed. Mineral fibre within cavity. Approximate mass per unit area 52 kg/m².
60+ Rw dB	<ol style="list-style-type: none"> 1. Two separate frames of metal 48 mm "C" studs 600 mm centres, clad both sides with a double layer 15 mm plasterboard, joints filled and perimeters sealed. Minimum overall width of 200 mm. Mineral fibre within cavity. Approximate mass per unit area 55 kg/m².

Source: BS 8233:2014, Table E.1A

Example floor	Design specification options
Below 43 Rw dB	<ol style="list-style-type: none"> 1. Timber joist floor consisting of 22 mm tongued and grooved floor boarding or equivalent fixed directly to floor joists. Ceiling of 12.5 mm plasterboard and skim with no floor covering.
Above 43 Rw dB	<ol style="list-style-type: none"> 1. A concrete floor having mass per unit area not less than 365 kg/m², including any screed or ceiling finish directly bonded to the floor slab, together with a floating floor or resilient floor covering equivalent to rubber or sponge rubber underlay or thick cork tile (e.g. carpet and underlay or sponge rubber backed vinyl flooring). 2. A solid floor consisting of: <ul style="list-style-type: none"> — a solid slab; or — concrete beams and infilling blocks; or — hollow concrete planks, — together with a floating floor. A ceiling finish is required for a beam and block floor. In each case the slab is to have a mass per unit area of at least 300 kg/m², including any screed or ceiling finish directly bonded to it. — Where a floating floor is laid over a floor of beams and hollow infill blocks or hollow beams along the top of the structural floor, the latter is to be sealed and levelled before the resilient layer is put down. It is also essential to have due regard for conduits and pipework to be laid and covered so as to prevent any short circuit of the floor's isolating properties. If precast units are used as a structural floor it is essential that the joints are filled to ensure that the sound insulation performance is maintained. — The resilient material is laid to cover completely the structural floor and turned up against the surrounding wall along all edges. The resilient layer is usually of mineral fibre, or a special grade of expanded polystyrene. When the screed is laid, it is important that none of the mix finds its way through the resilient layer to the structural floor, as this short-circuits the isolation between the two decks and significantly reduces the sound insulation. 3. A floor consisting of boarding nailed to battens laid to float upon an isolating layer of mineral fibre capable of retaining its resilience under imposed loading. With battens running along the joists, a dense fibre layer can be used in strips. The ceiling below to be of metal lath and plaster not less than 29 mm thick, with pugging on the ceiling such that the combined mass per unit area of the floor, ceiling and pugging is not less than 120 kg/m². 4. A floor consisting of 18 mm tongued and grooved chipboard on 19 mm plasterboard, laid on battens running parallel to the joists and supported on 25 mm thick mineral wool of approximately 90 kg/m³ to 140 kg/m³ density; 100 mm of fibre absorbent (as used for insulation in roof spaces) laid between the joists on top of the plasterboard ceiling. The ceiling can be 19 mm plus 12.5 mm plasterboard. It is imperative that the resilient layer is not punctured by nails. 5. A floor consisting of 18 mm tongued and grooved chipboard on 19 mm plasterboard floating on a 25 mm thick mineral wool layer of approximately 60 kg/m³ to 80 kg/m³ density; this on a 12.5 mm plywood platform; 100 mm of fibre absorbent laid between the joists on top of the plasterboard ceiling. The ceiling can be 19 mm plus 12.5 mm plasterboard. It is imperative that the resilient layer is not punctured by nails.

Source: BS 8233:2014, Table E.2A

External Noise Acoustics

Noise comes from a range of common sources such as including road traffic, aircraft, railways, industrial activities and people. The characteristics of the noise varies depending on its source so we have given some brief guidance below as to the likely noise levels and how these may be controlled for each of these main sources.

Typical permitted levels are as follows:

Area	Daytime dB level	Nighttime dB level
Industrial	75	70
Commercial	65	55
Residential	55	45
Silence zone	50	40

Note (Environment (Protection) Rules, 1986):

1. Daytime is reckoned in between 6am and 9pm.
2. Nighttime is reckoned in between 9pm and 6am.
3. Silence zone is referred to as areas up to 100 meters around such premises as hospitals, educational institutions and courts. The Silence zones are to be declared by the Competent Authority. Use of vehicular horns, loudspeakers and bursting of crackers shall be banned in these zones.
4. Mixed categories of areas should be declared as one of the four above mentioned categories by the Competent Authority and the corresponding standards shall apply.

Part 6 Chapter 2 of the Clean Neighbours and Environmental Act 2005 covers legal responsibilities and rights in relation to external noise pollution.

The Planning Practice Guidance (PPG) provides planning guidance on noise mitigation. Whereas the previous guidance (Planning policy guidance 24) was prescriptive about threshold noise levels the PPG adopts an approach that is contextual. While Local Plans can include noise standards, Paragraph: 010 Reference ID: 30-010-20140306 cautions against fixed thresholds.

The PPG refers to the Noise Policy Statement for England which explains the importance of noise mitigation but provides little technical detail. However the Building Standards (BS 8233:2014) provides guidance on sound insulation and noise reduction in and around buildings and directly responds to the withdrawal of planning guidance and policy statement documents on noise. Key elements of this guidance covering walls and floors are on pages 120 to 122.

With regard to a consideration of noise in a mixed use context, of particular relevance to LLDC is the following from Paragraph: 006 Reference ID: 30-006-20141224:

“The potential effect of a new residential development being located close to an existing business that gives rise to noise should be carefully considered. This is because existing noise levels from the business even if intermittent (for example, a live music venue) may be regarded as unacceptable by the new residents and subject to enforcement action. To help avoid such instances, appropriate mitigation should be considered, including optimising the sound insulation provided by the new development’s building envelope.”

Road Traffic

Road traffic noise generation depends upon a number of factors including meteorological conditions, topographical features and ground cover characteristics.

For a typical urban situation where road speed is around 30 miles per hour the sound energy is concentrated in the low frequency levels. At greater speeds more energy is present at higher frequencies due to the road/tyre surface interaction and aerodynamic noise. This difference in spectral characteristics can affect the nature of the noise heard within a building, and should be considered when different noise control measures are being examined.

Typical noise levels which may be experienced, measured approximately 1m from the façade of a building, are as summarised below:

Location	Summary of conditions	dB level
Residential road	Road parallel to a main road screened by the houses from the main road.	58
20m from a busy main road	Through a residential area average speed 50Km/h with pavements.	68
20m from a busy motorway	Heavy vehicles, high speeds 100Km/h and turfed reservation.	78

Noise source	Noise exposure category			
	A	B	C	D
Road traffic				
7.00-23.00	≤55	55-63	63-72	≥72
23.00- 7.00	≤45	45-57	57-66	≥66
Rail traffic				
7.00-23.00	≤55	55-66	66-74	≥74
23.00- 7.00	≤45	45-59	59-66	≥66
Air traffic				
7.00-23.00	≤57	57-66	66-72	≥72
23.00- 7.00	≤48	48-57	57-66	≥66
Mixed sources				
7.00-23.00	≤55	55-63	63-72	≥72
23.00- 7.00	≤45	45-57	57-66	≥66

Noise from Industry

Noise experienced as a result of industry is formed from a mix of sources which may be due to deliveries and people flow, external mechanical equipment or the operations and processes which are being carried out from within the facility.

As with all these external sources the proximity and treatment of the separating area play a key role in reducing or amplifying the noise levels experienced at the site boundary.

Where industrial noise affects residential or mixed residential areas, the methods for rating the noise in BS 4142 should be applied.

Planning applications will require a noise assessment be carried out prior to allowing new industrial activities to be carried out in order to determine the existing background noise levels and set an acceptable noise level generated by the facility in occupation.

Construction Activities

Similarly with industrial operations, construction noise levels may be dictated during the planning process. These will also control the periods of time when construction operations can be carried out in order to reduce the impact on surrounding occupants.

BS 5228-1 gives recommendations for basic methods of noise control for construction and opens sites where work/activities/operations, including demolition, generate significant noise levels.

The main factors that affect the acceptability of noise arising from construction sites are:

- site location;
- existing background noise levels;
- duration of site operations;
- hours of work;
- community involvement/ negotiation
- noise characteristics; and
- mitigation measures implemented.

The noise restriction imposed on a site will be determined by its proximity to neighbouring residents taking into consideration the site topography, orientation and wind direction as well as the current background noise levels.

As a guide it is suggested that the maximum noise levels near a construction site should be limited to 75 dB(A) Leq(1 hr.) in industrial areas and to 65 dB(A) Leq(5 min.) in other areas.



AECOM Infrastructure and
Environment UK Limited
6-8 Greencoat Place
London
Victoria
SW1P 1PL
T+44 (0) 207 798 5000
www.aecom.com

XXXXXXXXXXXXXXXXXXXXXXXXXXXX

WE MADE THAT

XXXXXXXXXXXXXXXXXXXXXXXXXXXX

WE MADE THAT LLP
studio@wemadethat.co.uk

30-32 Stamford Road
London N1 4JL
T +44 (0)20 7249 6336
www.wemadethat.co.uk

We Made That LLP is
registered in England &
Wales at the above address
Reg. no. OC367789